



DIRECTORATE OF TECHNICAL EDUCATION

DIPLOMA IN AGRICULTURAL TECHNOLOGY

Course Code: 1222

2015-2016

M - SCHEME

SYLLABUS

Syllabus Revision Committee
Diploma in Agricultural Technology (M-Scheme)

Chairperson

Tmt. S. Madumathi, I.A.S.,
 Director of Technical Education
 Directorate of Technical Education
 Chennai – 600 025.

Convener

K.R. MUTHUSWAMY
 PRINCIPAL (IC)
 Sakthi Polytechnic College
 Sakthi Nagar – 638 315.

List of Committee Members

1	Thiru R. Sathyamoorthy, Lecturer (Sel. Grade) /Agri. Tech., Sakthi Polytechnic College, Sakthi Nagar – 638 315.	6	Thiru Viswanathan, Principal, Kongu Vellalar Polytechnic College, Seenapuram, PERUNDURAI.
2	Thiru T.A. Mohamed Issac, Lecturer (Sel. Grade)/Agri. Tech., Sakthi Polytechnic College, Sakthi Nagar – 638 315.	7	Thiru Ashok kumar, Assistant General Manager, Sakthi Sugars Ltd., Sakthi Nagar – 638 315.
3	Thiru P. Boopathi, Lecturer (Sen. Grade)/Agri. Tech., Sakthi Polytechnic College, Sakthi Nagar – 638 315.	8	Thiru V. Muralidhar, Senior Manager – Marketing, Eicher Tractors, Huzur Gardens, Sembiam, CHENNAI – 600 011.
4	Thiru K.R. Palanisamy, Lecturer (Sel. Grade)/Civil, Sakthi Polytechnic College, Sakthi Nagar – 638 315.	9	Dr. C. Divaker Durairaj, M.E.,(Ag), Ph.D., Dean (Engg.)/c., Agricultural Engg. College & Research Institute, TNAU, COIMBATORE – 641 003
5	Thiru P. Ramalingam, Lecturer (Sel. Grade)/Mechanical, Muthiah Polytechnic College, Annamalai Nagar.	10	Smt. K. SIVAGANGAI M.E.(Agri.Engg.) LECTURER (AGI.TECH.) Muthiah Polytechnic College ANNAMALAINAGAR, CHIDAMBARAM

DIPLOMA COURSES IN ENGINEERING/TECHNOLOGY
(SEMESTER SYSTEM)

(Implemented from 2015- 2016)

M – SCHEME

REGULATIONS*

* *Applicable to the Diploma Courses other than Diploma in Hotel Management & Catering Technology and the Diploma Courses offered through MGR Film Institute, Chennai.*

1. Description of the Course:

a. Full Time (3 years)

The Course for the full Time Diploma in Engineering shall extend over a period of three academic years, consisting of 6 semesters* and the First Year is common to all Engineering Branches.

b. Sandwich (3½ years)

The Course for the Diploma in Engineering (sandwich) shall extend over a period of three and half academic years, consisting of 7 semesters* and the First Year is common to all Engineering Branches. The subjects of three years full time diploma course being regrouped for academic convenience.

During 4th and/or during 7th semester the students undergo industrial training for six months/ one year. Industrial training examination will be conducted after completion of every 6 months of industrial training

c. Part Time (4 years)

The course for the diploma in Engineering shall extend over a period of 4 academic years containing of 8 semesters*, the subjects of 3 year full time diploma courses being regrouped for academic convenience.

* Each Semester will have 15 weeks duration of study with 35 hrs. /Week for Regular Diploma Programme and 18hrs/ week (21 hrs. / Week 1 year) for Part-Time Diploma Programmes.

The Curriculum for all the 6 Semesters of Diploma courses (Engineering & Special Diploma Courses viz. Textile Technology, Leather Technology, Printing Technology, Chemical Technology etc.) have been revised and revised curriculum is applicable for the candidates admitted from 2015 – 2016 academic year onwards.

2. Condition for Admission:

Condition for admission to the diploma courses shall be required to have passed in

The S.S.L.C Examination of the Board of Secondary Education, TamilNadu.

(Or)

The Anglo Indian High School Examination with eligibility for Higher Secondary Course in TamilNadu.

(Or)

The Matriculation Examination of Tamil Nadu.

(Or)

Any other Examination recognized as equivalent to the above by the Board of Secondary Education, TamilNadu.

Note: In addition, at the time of admission the candidate will have to satisfy certain minimum requirements, which may be prescribed from time to time.

3. Admission to Second year (Lateral Entry):

A pass in HSC (Academic) or (Vocational) courses mentioned in the Higher Secondary Schools in TamilNadu affiliated to the TamilNadu Higher Secondary Board with eligibility for university Courses of study or equivalent examination, & Should have studied the following subjects.

Sl. No	Courses	H.Sc Academic	H.Sc Vocational	
		Subjects Studied	Subjects Studied	
			Related subjects	Vocational subjects
1.	All the Regular and Sandwich Diploma Courses	Maths, Physics & Chemistry	Maths / Physics / Chemistry	Related Vocational Subjects Theory & Practical
2.	Diploma course in Modern Office Practice	English & Accountancy English & Elements of Economics English & Elements of Commerce	English & Accountancy, English & Elements of Economics, English & Management Principles & Techniques, English & Typewriting	Accountancy & Auditing, Banking, Business Management, Co-operative Management, International Trade, Marketing & Salesmanship, Insurance & Material Management, Office Secretaryship.

- For the diploma Courses related with Engineering/Technology, the related / equivalent subjects prescribed along with Practical may also be taken for arriving the eligibility.
- Branch will be allotted according to merit through counseling by the respective Principal as per communal reservation.
- For admission to the Textile Technology, Leather Technology, Printing Technology, Chemical Technology and Modern Office Practice Diploma courses the candidates studied the related subjects will be given first preference.
- *Candidates who have studied Commerce Subjects are not eligible for Engineering Diploma Courses.*

4. Age Limit: No Age limit.

5. Medium of Instruction: English

6. Eligibility for the Award of Diploma:

No candidate shall be eligible for the Diploma unless he/she has undergone the prescribed course of study for a period of not less than 3 academic years in any institution affiliated to the State Board of Technical Education and Training, TamilNadu, when joined in First Year and two years if joined under Lateral Entry scheme in the second year and passed the prescribed examination.

The minimum and maximum period for completion of Diploma Courses are as given below:

Diploma Course	Minimum Period	Maximum Period
Full Time	3 Years	6 Years
Full Time(Lateral Entry)	2 Years	5 Years
Sandwich	3½ Years	6½ Years
Part Time	4 Years	7 Years

7. Subjects of Study and Curriculum outline:

The subjects of study shall be in accordance with the syllabus prescribed from time to time, both in theory and practical. The curriculum outline is given in Annexure - I

8. Examinations:

Board Examinations in all subjects of all the semesters under the scheme of examinations will be conducted at the end of each semester.

The Internal assessment marks for all the subjects will be awarded on the basis of continuous internal assessment earned during the semester concerned. For each subject 25 marks are allotted for internal assessment and 75 marks are allotted for Board Examination.

9. Continuous Internal Assessment:

A . For Theory Subjects:

The Internal Assessment marks for a total of 25 marks, which are to be distributed as follows:

i. Subject Attendance

5 Marks

(Award of marks for subject attendance to each subject theory/practical will as per the range given below)

80% - 83%	}	1 Mark
84% - 87%		2 Marks
88% - 91%		3 Marks
92% - 95%		4 Marks
96% - 100%		5 Marks

ii) Test #

10 Marks

2 Tests each of 2 hours duration for a total of 50 marks are to be conducted. Out of which the best one will be taken and the marks to be reduced to: 05 marks

The Test – III is to be the Model test covering all the five units and the marks so obtained will be reduced to : 05 marks

Total 10 marks

TEST	UNITS	WHEN TO CONDUCT	MARKS	DURATION
Test I	Unit – I & II	End of 6 th week	50	2 Hrs
Test II	Unit – III & IV	End of 12 th week	50	2 Hrs
Test III	Model Examination - Compulsory Covering all the 5 Units. (Board Examination-question paper-pattern).	End of 15 th week	75	3 Hrs

- From the Academic year 2015-2016 onwards.

Question Paper Pattern for the Periodical Test :(Test - I & Test- II)

With no choice:

PART A type questions:	4 Questions X 2 mark	8 marks
PART B type questions:	4 Questions X 3 marks	12 marks
PART C type questions:	3 Questions X 10 marks	30 marks

Total 50 marks

iii) Assignment

10 Marks

For each subject Three Assignments are to be given each for 20 marks and the average marks scored should be reduced for 10 marks

All Test Papers and assignment notebooks after getting the signature with date from the students must be kept in the safe custody in the Department for verification and audit. It should be preserved for 2 Semesters and produced to the flying squad and the inspection team at the time of inspection/verification.

B. For Practical Subjects:

The internal assessment mark for a total of 25 marks which are to be distributed as follows:-

a)	Attendance	:	5 Marks
	(Award of marks as same as Theory subjects)		
b)	Procedure/ observation and tabulation/ Other Practical related Work	:	10 Marks
c)	Record writing	:	10 Marks

	TOTAL	:	25 Marks

- *All the Experiments/exercises indicated in the syllabus should be completed and the same to be given for final board examinations.*
- The Record for every completed exercise should be submitted in the subsequent Practical classes and marks should be awarded for 20 for each exercise as per the above allocation.
- At the end of the Semester, the average marks of all the exercises should be calculated for 20 marks and the marks awarded for attendance is to be added to arrive at the internal assessment mark for Practical. (20+5=25 marks)
- The students have to submit the duly signed bonafide record note book/file during the Practical Board Examinations.

- All the marks awarded for assignment, Test and attendance should be entered in the Personal Log Book of the staff, who is handling the subject. This is applicable to both Theory and Practical subjects.

10. Life and Employability Skill Practical:

The Life and Employability Skill Practical with more emphasis is being introduced in IV Semester for Circuit Branches and in V Semester for other branches of Engineering.

Much Stress is given to increase the employability of the students:

Internal assessment Mark **25 Marks**

11. Project Work:

The students of all the Diploma Programmes (**except Diploma in Modern Office Practice**) have to do a Project Work as part of the Curriculum and in partial fulfillment for the award of Diploma by the State Board of Technical Education and Training, Tamilnadu. In order to encourage students to do worthwhile and innovative projects, every year prizes are awarded for the best three projects i.e. institution wise, region wise and state wise. **The Project work must be reviewed twice in the same semester.**

a) Internal assessment mark for Project Work & Viva Voce:

Project Review I	...	10 marks
Project Review II	...	10 marks
Attendance	...	05 marks (award of marks same as theory subjects pattern)

Total	...	25 marks

Proper record to be maintained for the two Project Reviews, and It should be preserved for 2 Semesters and produced to the flying squad and the inspection team at the time of inspection/verification.

b) Allocation of Mark for Project Work & Viva Voce in Board Examination:

Viva Voce	...	30 marks
Marks for Report Preparation, Demo	...	35 marks

	Total	65 marks

c) Written Test Mark (from 2 topics for 30 minutes duration): \$

i) Environment Management	2 questions X 2 ½ marks	= 5 marks
ii) Disaster Management	2 questions X 2 ½ marks	= 5 marks

		10marks

\$ - Selection of Questions should be from Question Bank, by the External Examiner.

No choice need be given to the candidates.

Project Work & Viva Voce in Board Examination	--	65 Marks
Written Test Mark (from 2 topics for 30 minutes duration)	--	10 Marks
TOTAL	--	75 Marks

A neatly prepared PROJECT REPORT as per the format has to be submitted by individual during the Project Work & Viva Voce Board examination.

12. Scheme of Examinations:

The Scheme of examinations for subjects is given in **Annexure - II**.

13. Criteria for Pass:

1. No candidate shall be eligible for the award of Diploma unless he/she has undergone the prescribed course of study successfully in an institution approved by AICTE and affiliated to the State Board of Technical Education & Training, Tamil Nadu and pass all the subjects prescribed in the curriculum.
2. A candidate shall be declared to have passed the examination in a subject if he/she secures not less than *40% in theory subjects* and *50% in practical subject* out of the total prescribed maximum marks including both the internal assessment and the Board Examination marks put together, subject to the condition that he/she secures at least a minimum of *30 marks out of 75 marks in the Board's Theory examinations and a minimum of 35 marks out of 75 marks in the Board Practical Examinations.*

14. Classification of successful candidates:

Classification of candidates who will pass out the final examinations from April 2018 onwards (Joined in first year in 2015-2016) will be done as specified below.

First Class with Superlative Distinction:

A candidate will be declared to have passed in **First Class with Superlative Distinction** if he/she secures not less than 75% of the marks in all the subjects and passes all the semesters in the first appearance itself and passes all subjects within the stipulated period of study 3/ 3½/ 4 years (Full Time/Sandwich/Part Time) without any break in study.

First Class with Distinction:

A candidate will be declared to have passed in **First Class with Distinction** if he/she secures not less than 75% of the aggregate of marks in all the

semesters put together and passes all the semesters except the I and II semesters in the first appearance itself and passes all the subjects within the stipulated period of study 3/ 3½/ 4 years (Full Time/Sandwich/Part Time) without any break in study.

First Class:

A candidate will be declared to have passed in **First Class** if he/she secures not less than 60% of the aggregate marks in all semesters put together and passes all the subjects within the stipulated period of study 3/ 3½ / 4 years (Full Time/Sandwich/Part Time) without any break in study.

Second Class:

All other successful candidates will be declared to have passed in **Second Class**.

The above mentioned classifications are also applicable for the Sandwich / Part-Time students who pass out Final Examination from October 2018 /April 2019 onwards (both joined in First Year in 2015-2016)

15. Duration of a period in the Class Time Table:

The duration of each period of instruction is 1 hour and the total period of instruction hours excluding interval and Lunch break in a day should be uniformly maintained as 7 hours corresponding to 7 periods of instruction (Theory & Practical).

16. Seminar:

For seminar the total seminar 15 hours(15 weeks x 1hour) should be distributed equally to total theory subject per semester(i.e 15 hours divided by 3/4 subject). A topic from subject or current scenario is given to students. During the seminar hour students have to present the paper and submit seminar material to the respective staff member, who is handling the subject. It should be preserved for 2 Semesters and produced to the flying squad and the inspection team at the time of inspection/verification.

-xXx-

M SCHEME
CURRICULUM OUTLINE
DIPLOMA IN AGRICULTURAL TECHNOLOGY

THIRD SEMESTER

Subjects	Subject	HOURS PER WEEK			
		Theory Hours	Tutorial / Drawing	Practical Hours	Total Hours
32031	Strength of Materials*	6	-	-	6
32332	Principles of Crop Production	5	-	-	5
32033	Machine Drawing *	-	4	-	4
32334	Surveying and Levelling	5	-	-	5
32335	Principles of Crop Production Practical	-	-	4	4
32336	Surveying and Levelling Practical	-	-	6	6
30001	Computer Applications Practical **	-	-	4	4
	Seminar	1			1
TOTAL		17	4	14	35

* Common to Mechanical Engineering Course

** Common to all Diploma Courses

M SCHEME - CURRICULUM OUTLINE
DIPLOMA IN AGRICULTURAL TECHNOLOGY

FOURTH SEMESTER

Subjects Code	Subject	HOURS PER WEEK			
		Theory Hours	Tutorial / Drawing	Practical Hours	Total Hours
32341	Fluid mechanics	6	-	-	6
32342	Soil & Water Conservation Engineering	5	-	-	5
32343	Irrigation Engineering	5	-	-	5
32044	Electrical Drives & Control *	6	-	-	6
32345	Mechanical Testing & Fluid Power Practical	-	-	4	4
32346	Computer Aided Drawing Practical	-	-	4	4
32047	Electrical Drives & Control Practical*	-	-	4	4
	Seminar	1	-	-	1
	TOTAL	23	-	12	35

* Common to Mechanical Engineering Course

** Common to all Diploma Courses

M SCHEME
CURRICULUM OUTLINE
DIPLOMA IN AGRICULTURAL TECHNOLOGY

FIFTH SEMESTER

Subject No.	Subject	HOURS PER WEEK			
		Theory Hours	Tutorial / Drawing	Practical Hours	Total Hours
32351	Tractor and Its Power Units	6	-	-	6
32352	Farm Machinery	6	-	-	6
Elective Theory - I					
32371	1. Post Harvest Technology	5	-	-	5
32372	2. Food Process Engineering				
32073	3. Renewable Energy Sources and Energy Conservation*				
32354	Tractor and Its Power Units Practical	-	-	4	4
32055	Process Automation Practical*	-	-	4	4
32356	Machine shop-I Practical (Lathe and Welding)	-	-	5	5
30002	Life and Employability Skill Practical **	-	-	4	4
	Seminar	1	-	-	1
	Total	18	-	17	35

* Common to Mechanical Engineering Course

** Common to all Diploma Courses

M SCHEME
CURRICULUM OUTLINE
DIPLOMA IN AGRICULTURAL TECHNOLOGY

SIXTH SEMESTER

Subject Code	Subjects	Hours per weak			
		Theory	Tutorial	Practical	Total Hours
32061	Industrial Engineering & Management*	6	-	-	6
32062	Computer Aided Design and Manufacturing *	5	-	-	5
	Elective Theory – II				
32381	1. Sugarcane Crop Production	5	-	-	5
32382	2.Dairy Engineering				
32383	3. Manufacturing Engineering				
32064	Computer Aided Design and Manufacturing Practical*	-	-	6	6
32365	Farm Machinery Practical	-	-	4	4
32366	Machine shop-II Practical (Milling & Grinding)	-	-	4	4
32367	Project Work**	-	-	4	4
	Seminar	1	-	-	1
	Total	17	-	18	35

* Common to Mechanical Engineering Course

** Common to all Diploma Courses

ANNEXURE - II
SCHEME OF THE EXAMINATION

THIRD SEMESTER

Subject Code	SUBJECT	Examination Marks			Minimum for pass	Duration of Exam Hours
		Internal assessment Marks	Board Exam. Marks	Total Mark		
32031	STRENGTH OF MATERIALS*	25	75	100	40	3
32332	PRINCIPLES OF CROP PRODUCTION	25	75	100	40	3
32033	MACHINE DRAWING*	25	75	100	40	3
32334	SURVEYING AND LEVELLING	25	75	100	40	3
32335	PRINCIPLES OF CROP PRODUCTION PRACTICAL	25	75	100	50	3
32336	SURVEYING AND LEVELLING PRACTICAL	25	75	100	50	3
30001	COMPUTER APPLICATION PRACTICAL**	25	75	100	50	3
TOTAL		175	525	700		

* Common to Mechanical Engineering Course

** Common to all Diploma Courses

FOURTH SEMESTER

Subject Code	SUBJECT	Examination Marks			Minimum for pass	Duration of Exam Hours
		Internal assessment Marks	Board Exam Marks	Total Mark		
32341	FLUID MECHANICS	25	75	100	40	3
32342	SOIL & WATER CONSERVATION ENGINEERING	25	75	100	40	3
32343	IRRIGATION ENGINEERING	25	75	100	40	3
32044	ELECTRICAL DRIVES & CONTROL *	25	75	100	40	3
32345	MECHANICAL TESTING & FLUID POWER PRACTICAL	25	75	100	50	3
32346	COMPUTER AIDED DRAWING PRACTICAL	25	75	100	50	3
32047	ELECTRICAL DRIVES & CONTROL PRACTICAL*	25	75	100	50	3
TOTAL		175	525	700		

* Common to Mechanical Engineering Course

** Common to all Diploma Courses

FIFTH SEMESTER

Subject Code	SUBJECT	Examination Marks			Minimum for pass	Duration of Exam Hours
		Internal assessment Marks	Board Exam Marks	Total Mark		
32351	TRACTOR AND ITS POWER UNITS	25	75	100	40	3
32352	FARM MACHINERY	25	75	100	40	3
ELECTIVE THEORY - I						
32371	1. POST HARVEST TECHNOLOGY	25	75	100	40	3
32372	2.FOOD PROCESS ENGINEERING					
32073	3.RENEWABLE ENERGY SOURCES AND ENERGY CONSERVTION*					
32354	TRACTOR AND ITS POWER UNITS PRACTICALS	25	75	100	50	3
32055	PROCESS AUTOMATION PRACTICAL*	25	75	100	50	3
32356	MACHINE SHOP I PRACTICAL (LATHE AND WELDING)	25	75	100	50	3
30002	Life and Employability Skill Practical**	25	75	100	50	3
TOTAL		175	525	700		

* Common to Mechanical Engineering Course

** Common to all Diploma Courses

SIXTH SEMESTER

Subject Code	SUBJECT	Examination Marks			Minimum for pass	Duration of Exam Hours
		Internal assessment Marks	Board Exam Marks	Total Mark		
32061	INDUSTRIAL ENGINEERING & MANAGEMENT*	25	75	100	40	3
32062	COMPUTER AIDED DESIGN AND MANUFACTURING*	25	75	100	40	3
ELECTIVE THEORY - II						
32381	1.SUGARCANE CROP PRODUCTION	25	75	100	40	3
32382	2.DAIRY ENGINEERING					
32383	3.MANUFACTURING ENGINEERING					
32064	COMPUTER AIDED DESIGN AND MANUFACTURING PRACTICAL*	25	75	100	50	3
32365	FARM MACHINERY PRACTICAL	25	75	100	50	3
32366	MACHINE SHOP II PRACTICAL (MILLING & GRINDING)	25	75	100	50	3
32367	PROJECT WORK**	25	75	100	50	3
TOTAL		175	525	700		

*** COMMON WITH MECHANICAL ENGINEERING**

****COMMON FOR ALL BRANCHES**

Board Examination - Question paper pattern
Common for all theory subjects except Machine Drawing

Question paper pattern

PART A - (1 to 8) 5 Questions are to be answered out of 8 questions for 2 marks each. (Question No. 8 will be the compulsory question and can be asked from any one of the units) (From each unit maximum of two 2 marks questions alone can be asked)

PART B - (9 to 16) 5 Questions are to be answered out of 8 questions for 3 marks each. (Question No. 16 will be the compulsory question and can be asked from any one of the units) (From each unit maximum of two 3 marks questions alone can be asked)

PART C - (17 to 21) Five Questions will be in the Either OR Pattern. Students have to answer these five questions. Each question carries 10 marks. (Based on the discretion of the question setter, he/she can ask two five mark questions (with sub division A & sub division B) instead of one ten marks question if required)

V SEMESTER - [W.E.F OCT '17] L - SCHEME**M-SCHEME**

Sl. No	Subjects Code	Name of Subject	Subject code	Name of Subject
1	22351	Tractor & Its Power Units	32351	Tractor and Its Power Units
2	22352	Farm Machinery	32352	Farm Machinery
Elective Theory:				
3	22371	Micro Irrigation	32343	Irrigation Engineering
	22372	Manufacturing Technology	32383	Manufacturing Engineering
	22373	Food Process Engineering	32372	Food Process Engineering
4	22354	SUGARCANE CROP PRODUCTION	32381	SUGARCANE CROP PRODUCTION
5	22355	Tractor and Its Power Units Practical	32354	Tractor and Its Power Units Practical
6	22056	Manufacturing Technology-II Practical*	32366	Machine shop – II Practical (Milling & Grinding)
7	30002	Life and Employability Skill Practical **	30002	Life and Employability Skill Practical **

VI SEMESTER - [W.E.F APR ' 18] L - SCHEME**M-SCHEME**

Sl.No	Subjects Code	Name of Subject	Subject code	Name of Subject
1	22061	Industrial Engineering & Management*	32061	Industrial Engineering & Management*
2	22062	Computer Integrated Manufacturing *	32062	Computer Aided Design and Manufacturing *
Elective Theory:				
3	22381	Sugarcane Harvester operations & Maintenance	32382	Dairy Engineering
	22382	Post Harvest Technology	32371	Post Harvest Technology
	22033	Renewable sources*	32073	Renewable Energy Sources and Energy Conservation*
4	22064	Computer Integrated Manufacturing Practical *	32064	Computer Aided Design and Manufacturing Practical*
5	22065	Process Automation Practical*	32055	Process Automation Practical*
6	22366	Farm Machinery Practical	32365	Farm Machinery Practical
7	22367	Project Work**	32367	Project Work**

III SEMESTER



DIRECTORATE OF TECHNICAL EDUCATION

DIPLOMA IN AGRICULTURAL TECHNOLOGY

II YEAR

M SCHEME

III SEMESTER

2015-2016 (on wards)

STRENGTH OF MATERIALS

CURRICULUM DEVELOPMENT CENTRE

M-SCHEME

(Implements from the Academic year 2015-2016 onwards)

Course Name : DIPLOMA IN AGRICULTURAL TECHNOLOGY
Course Code : 1222
Subject Code : 32031
Semester : III
Subject Title : **STRENGTH OF MATERIALS**

TEACHING AND SCHEME OF EXAMINATIONS:

No. of Weeks per Semester: 15 Weeks

Subject	Instructions		Examination			Duration
	Hours / Week	Hours / Semester	Marks			
Strength of Materials	6	90	Internal Assessment	Board Examination	Total	3 Hrs
			25	75	100	

Topics and Allocation of Hours:

Unit No	Topics	Hours
I	STATICS OF PARTICLE AND FRICTION	17
II	MECHANICAL PROPERTIES, SIMPLE STRESSES AND STRAINS	17
III	GEOMETRICAL PROPERTIES OF SECTIONS AND THIN SHELLS	17
IV	SHEAR FORCE AND BENDING MOMENT DIAGRAMS, THEORY OF SIMPLE BENDING	16
V	TORSION AND SPRINGS	16
	TEST AND REVISION	7
	Total	90

RATIONALE:

Day by day, engineering and technology experience tremendous growth. Design plays a major role in developing engineering and technology. Strength of material is backbone for design. The strength of material deals generally with the behaviour of objects, when they are subject to actions of forces. Evaluations derived from these basic fields provide the tools for investigation of mechanical structure.

OBJECTIVES

- Define various Support reaction and equilibrium.
- Calculate the deformation of materials, which are subjected to axial load and shear.
- Determine the moment of Inertia of various sections used in industries.
- Estimate the stresses induced in thin shells.
- Draw the shear force and bending moment diagram of the beam for different loads.

32031 STRENGTH OF MATERIALS

DETAILED SYLLABUS

Contents: Theory

Unit	Name of the Topic	Hours
I	STATICS OF PARTICLES: Introduction – Force - effects of a force - system of forces - resultant of force - Principle of transmissibility - parallelogram law of forces - triangular law - resultant of several forces acting on a particle - polygon law - resolution of a force into rectangular components – resultant of a system of forces acting on a particle using rectangular components - equilibrium of particles. External and internal forces - moment of a force - Varignon's theorem - moment of a couple - equivalent couples - addition of couples - resolution of a force into a force and a couple - Free body diagram - Necessary and sufficient conditions for the equilibrium of rigid bodies in two dimension - Support reaction - types of support - removal of two dimensional supports - Simple problems only. FRICITION: Introduction - Definition - Force of friction - Limiting friction - Static friction - Dynamic friction - Angle of friction - co-efficient of friction - Laws of static and dynamic friction.	17
II	DEFORMATION OF METALS Mechanical properties of materials: Engineering materials – Ferrous and non-ferrous materials - Definition of mechanical properties - Alloying elements-effect of alloying element - Fatigue, fatigue strength, creep – temperature creep – cyclic loading and repeated loading – endurance limit. Simple stresses and strains: Definition – Load, stress and strain – Classification of force systems – tensile, compressive and shear force systems – Behaviour of mild steel in tension up to rupture – Stress – Strain diagram – limit of proportionality – elastic limit – yield stress – breaking stress – Ultimate stress – percentage of elongation and	17

percentage reduction in area – Hooke's law – Definition – Young's modulus - working stress, factor of safety, load factor, shear stress and shear strain - modulus of rigidity. Linear strain – Deformation due to tension and compressive force – Simple problems in tension, compression and shear force.

Definition – Lateral strain – Poisson's ratio – volumetric strain – bulk modulus – volumetric strain of rectangular and circular bars – problems connecting linear, lateral and volumetric deformation – Elastic constants and their relationship - Problems on elastic constants - Definition – Composite bar – Problem in composite bars subjected to tension and compression – Temperature stresses and strains – Simple problems – Definition – strain energy – proof resilience – modulus of resilience – The expression for strain energy stored in a bar due to Axial load – Instantaneous stresses due to gradual, sudden, impact and shock loads – Problems computing instantaneous stress and deformation in gradual, sudden, impact and shock loadings.

III **GEOMETRICAL PROPERTIES OF SECTIONS AND THIN SHELLS** 17

Properties of sections: Definition – center of gravity and centroid - position of centroids of plane geometrical figures such as rectangle, triangle, circle and trapezium-problems to determine the centroid of angle, channel, T and I sections only - Definition-centroidal axis-Axis of symmetry. Moment of Inertia – Statement of parallel axis theorem and perpendicular axis theorem. Moment of Inertia of lamina of rectangle, circle, triangle, I and channel sections-Definition-Polar moment of Inertia-radius of gyration – Problems computing moment of inertia and radius of gyration for angle, T, Channel and I sections.

Thin Shells: Definition – Thin and thick cylindrical shell – Failure of thin cylindrical shell subjected to internal pressure – Derivation of Hoop and longitudinal stress causes in a thin cylindrical shell subjected to internal pressure – simple problems – change in dimensions of a thin cylindrical shell subjected to internal pressure –

problems – Derivation of tensile stress induced in a thin spherical shell subjected to internal pressure – simple problems – change in diameter and volume of a thin spherical shell due to internal pressure – problems.

IV SF AND BM DIAGRAMS OF BEAMS AND THEORY OF BENDING 16

Classification of beams – Definition – shear force and Bending moment – sign conventions for shear force and bending moment – types of loadings – Relationship between load, force and bending moment at a section – shear force diagram and bending moment diagram of cantilever and simply supported beam subjected to point load and uniformly distributed load (udl) – Determination of Maximum bending moment in cantilever beam and simply supported beam when they are subjected to point load and uniformly distributed load. Theory of simple bending – Assumptions – Neutral axis – bending stress distribution – moment of resistance – bending equation – $M/I = f/y = E/R$ – Definition – section modulus - rectangular and circular sections – strength of beam – simple problems involving flexural formula for cantilever and simple supported beam.

V THEORY OF TORSION AND SPRINGS 16

Theory of torsion – Assumptions – torsion equation $\frac{T}{J} = \frac{f_s}{R} = \frac{C\theta}{l}$ – strength of solid and hollow shafts – power transmitted – Definition – Polar modulus – Torsional rigidity – strength and stiffness of shafts – comparison of hollow and solid shafts in weight and strength considerations – Advantages of hollow shafts over solid shafts – Problems.

Types of springs – Laminated and coiled springs and applications – Types of coiled springs – Difference between open and closely coiled helical springs – closely coiled helical spring subjected to an axial load – problems to determine shear stress, deflection, stiffness and resilience of closed coiled helical springs

Text Books:

- 1) Strength of Materials, R. S. Khurmi, S.Chand & Co., Ram Nagar, New Delhi.
- 2) Strength of Materials, S. Ramamrutham, 15th Edn 2004, DhanpatRai Pub. Co., New Delhi.

Reference Books:

- 1) Strength of Materials, R.K. Bansal,, Laxmi Publications Pvt. Ltd., New Delhi, 3rd Edition, 2010.
- 2) Strength of materials, S.S.Rattan, Tata Mcgraw hill, New Delhi,2008, ISBN 9780070668959,
- 3) Strength of Materials, B K Sarkar, I Edition, 2003 Tata Mcgraw hill, New Delhi.
- 4) Engineering mechanics, R.K. Bansal, Laxmi Publications Pvt. Ltd., New Delhi, 2nd Edition, 2007



DIRECTORATE OF TECHNICAL EDUCATION

DIPLOMA IN AGRICULTURAL TECHNOLOGY

II YEAR

M SCHEME

III SEMESTER

2015-2016 (on wards)

PRINCIPLES OF CROP PRODUCTION

CURRICULUM DEVELOPMENT CENTRE

M – SCHEME

(Implements from the academic year 2015-2016 onwards)

Course Name : DIPLOMA IN AGRICULTURAL TECHNOLOGY
Course Code : 1222
Subject Code : 32332
Semester : III
Subject Title : PRINCIPLES OF CROP PRODUCTION

TEACHING AND SCHEME OF EXAMINATION:

No of weeks per semester: 15 Weeks

Subject	Instruction		Examination			Duration
	Hours /week	Hours /Semesters	Marks			
			Internal Assessment	Board Examination	Total	
Principles of crop Production	5 Hrs	75 Hrs	25	75	100	3 Hrs

Topics and Allocation of Hours:

Unit NO	Topic	Hours
I	INTRODUCTION	12
II	RICE	14
III	COTTON, GROUND NUT & COCONUT	14
IV	HORTICULTURAL CROPS – FRUITS	14
V	HORTICULTURAL CROPS – VEGETABLES	14
	REVISION AND TEST	7
	Total	75

RATIONALE:

The course is so designed to learn more about the recent advances made in crop production techniques for the crops prescribed viz., rice, sugarcane, cotton, groundnut, coconut and horticultural crops like Fruits and vegetables.

OBJECTIVES:

- To study the importance of rice and its cultivation techniques.
- To impart knowledge on the agronomic advancements of sugar yielding crop viz sugar cane.
- To study the cultivation details with reference to economically important fibre crop viz cotton
- To understand the importance of oil seed crops and cultivation techniques for ground nut and coconut.
- To study the importance of fruit crops in human nutrition and to know the cultivation techniques of mango, banana and grapes.
- To study the importance and cultivation details of common vegetable crops viz, brinjal, tomato, chillies and bendi.

32332 PRINCIPLES OF CROP PRODUCTION

DETAILED SYLLABUS

Contents: Theory

Unit	Name of the topic	Hours
I	INTRODUCTION Climate of Tamil Nadu-Weather-Climate-Microclimate-Importance of climate and its forecasting. Seasons of Tamil Nadu-Important seasons and crops of Tamil Nadu- Agro climatic zones-Factors affecting crop production-Climate-Soil factors-Biological factors. Soil fertility of Tamil Nadu-Functions of Soil-soil types of Tamil Nadu and its distribution. Characteristic of soil-Physical properties-Chemical properties-Biological Properties. Soil fertility and soil productivity-Methods of improving soil productivity-List of crops suitable for different soil types.	12Hrs
II	RICE Rice – soil and climatic requirement, seasons and varieties – Methods of sowing – nursery preparation and management, seed rate, pretreatment of Seeds- application of organic manure to the nursery –Forming nursery beds – Sowing – Age of seedlings – pulling out seedlings –main field preparation – transplanting – deficiency symptoms for major and micronutrients – correction – manures and manuring – time and method of fertilizer application – bio fertilizers – green and green leaf manuring – water management – weed management – pest and disease management –Harvesting – Systematic Rice Intensification (SRI) – Post Harvest technology. SUGARCANE Soil and climatic requirements – main field preparation – sett rate – sett treatment – planting techniques – gap filling – manures and manuring – Water management weed management – after cultivation practices – earthing up- Detrashing and propping – pest and disease management – use of cane ripeners – harvesting – Ratoon Management – Systematic Sugarcane Intensification (SSI)	14Hrs
III	COTTON, GROUNDNUT AND COCONUT COTTON Soil and climatic requirements – season and varieties – fields preparation seed rate – seed treatment – sowing – gap filling – thinning – manures and manuring – water management – weed management – pest and disease management –harvesting – rice fallow cotton cultivation – post harvest technology.	14Hrs

	<p>GROUNDNUT Soil and climatic requirements – season and varieties – field preparation – seed rate – seed treatment – sowing – Intercropping – manures and manuring – Gypsum application – Earthing up - weed management – water management – pest and disease management – Harvesting – Post harvest technology.</p> <p>COCONUT Soil and climatic requirements – seasons – varieties – preparation of nursery –planting techniques – manures and manuring – irrigation – weeding – pest and disease management – harvest and post harvest technology.</p>	
IV	<p>HORTICULTURAL CROPS – FRUITS</p> <p>1. MANGO Varieties, soil and climate, season of planting – propagation techniques, field preparation, planting – spacing – irrigation – intercropping – manures and manuring – pruning physiological disorders and remedy.</p> <p>2. BANANA Varieties – soil and climate – season of planting – selection and pre treatment of suckers – field preparation – digging pits – spacing – manures and manuring – plant growth regulators (PGR'S) – intercropping – harvesting and yield.</p> <p>3. GRAPES Varieties - Propagation – Field preparation – Spacing – irrigation – training and pruning – harvesting and yield.</p>	14Hrs
V	<p>HORTICULTURAL CROPS - VEGETABLES</p> <p>1. BRINJAL Varieties – soil – season of sowing and planting – nursery raising – preparation of field – fertilizer management – irrigation – use of PGR's – types of styles – yield – harvesting.</p> <p>2. TOMATO Varieties – soil – seed – nursery – season of sowing and planting – nursery raising – preparation of field – planting – fertilizer management – irrigation – maturity index – Harvesting and yield – seed extraction.</p> <p>3. CHILLIES Varieties – soil – Season of sowing – nursery and planting – preparation of field – fertilizer – irrigation – weed control – growth regulators – Harvesting and yield.</p> <p>4. BHENDI</p>	14Hrs

	Varieties – soil and climate – season and sowing – preparation of field – fertilizer–irrigation – application of PGR's – Harvesting and yield.	
--	--	--

Reference Books:

1. Handbook of agriculture – ICAR, Publication – New Delhi.
2. Handbook of Horticulture – ICAR. Publication – New Delhi.
3. Crop Production Techniques for Horticultural crops – TNAU, Coimbatore.
4. Crop Production guide – Directorate of Agriculture – Chepauk, Chennai.
Ahlawat, I.P.S., Prakash O.M. and Saini. G.S. 1999.
5. Scientific crop production India. Aman publishing house, madhu market, Budhana Gate, Meerut.



DIRECTORATE OF TECHNICAL EDUCATION

DIPLOMA IN AGRICULTURAL TECHNOLOGY

II YEAR

M SCHEME

III SEMESTER

2015-2016(on wards)

MACHINE DRAWING

CURRICULUM DEVELOPMENT CENTRE

M-SCHEME

(Implements from the Academic year 2015-2016 onwards)

Course Name : DIPLOMA IN AGRICULTURAL TECHNOLOGY
Course Code : 1222
Subject Code : 32033
Semester : III
Subject Title : **MACHINE DRAWING**

TEACHING AND SCHEME OF EXAMINATIONS:

No. of Weeks per Semester: 15 Weeks

Subject	Instructions		Examination			Duration
	Hours /Week	Hours/ Semester	Marks			
Machine Drawing	4	60	Internal Assessment	Board Examination	Total	3 Hrs
			25	75	100	

Topics and Allocation of Hours:

Unit	Topics	Hours
I	Sectional Views	5
II	Limits, Fits and Tolerances	5
III	Surface Texture	5
IV	Keys, Screw threads and Threaded fasteners	5
V	Assemble drawing	33
	TEST AND REVISION	7
	Total	60

RATIONALE:

Manufacturing of various parts start from the basic drawing of components. The assembly of components is also carried out from the drawing. So drawing is an important subject to be studied by the students to carry and complete the production and assembly process successfully.

OBJECTIVES:

- Appreciate the need for sectional view and types of sections.
- Draw sectional views using different types of sections.
- Explain the use of threaded fasteners and the types of threads.
- Compare hole basis system with shaft basis system.
- Select different types of fits and tolerance for various types of mating parts.
- Appreciate the importance of fits and tolerance.

32033 MACHINE DRAWING
DETAILED SYLLABUS

Contents: Theory

Unit	Name of the Topic	Hours
I	SECTIONAL VIEWS Review of sectioning – Conventions showing the section – symbolic representation of cutting plane- types of section – full section, half section, offset section, revolved section, broken section, removed section – section lining.	5
II	LIMITS, FITS AND TOLERANCES Tolerances – Allowances – Unilateral and Bilateral tolerances. Limits – Methods of tolerances – Indication of tolerances on linear dimension of drawings – Geometrical tolerances – application – Fits – Classifications of fits – Selection of fits – examples	5
III	SURFACE TEXTURE Surface texture – importance – controlled and uncontrolled surfaces – Roughness – Waviness – lay – Machining symbols	5
IV	KEYS, SCREW THREADS AND THREADED FASTENERS Types of fasteners – temporary fasteners – keys – classification of keys – Heavy duty keys – light duty keys. Screw thread – Nomenclature – different types of thread profiles – threads in sections – threaded fasteners – bolts – nuts – through bolt – tap bolt, stud bolt – set screw – cap screws – machine screws – foundation bolts.	5
V	MANUAL DRAWING PRACTICE Detailed drawings of following machine parts are given to students to assemble and draw the Elevations / Sectional elevations / Plan / and Side views with dimensioning and bill of materials 1. Sleeve & Cotter joint 2. Knuckle joint 3. Screw Jack 4. Foot step bearing 5. Plummer Block	33

6.	Universal Coupling	
7.	Simple Eccentric	
8.	Machine Vice	
9.	Protected type flanged coupling	
10.	Swivel bearing.	

Books:

- 1) Machine Drawing, P.S. Gill, Katsan Publishing House, Ludiana
- 2) A Text book of Engineering Drawing, R.B. Gupta, Satya Prakasan, Technical India Publications, New Delhi
- 3) Mechanical Draughtsmanship, G.L. Tamta, Dhanpat Rai & Sons, Delhi
- 4) Geometrical and Machine Drawing, N.D. Bhatt, Cheroter book stalls, Anand, West Railway
- 5) Engineering Drawing, D.N. Ghose, Dhanpat Rai & Sons, Delhi

BOARD EXAMINATIONS

Question Pattern

Time: 3 Hrs

Max Marks : 75

Note: All the questions will be answered in drawing sheet only

PART A: (7 x 5 = 35)

Theory questions: (1 TO 8)

Two questions from each unit (I to IV) will be asked.

Answer any seven questions from the given eight questions.

PART B: 40 Marks (Either A or B.)

Answer any one question by selecting either A or B.

9. A. Assemble and Draw any two views and bill of materials.

(OR)

- B. Assemble and Draw any two views and bill of material



DIRECTORATE OF TECHNICAL EDUCATION

DIPLOMA IN AGRICULTURAL TECHNOLOGY

II YEAR

M SCHEME

III SEMESTER

2015-2016(on wards)

SURVEYING & LEVELLING

CURRICULUM DEVELOPMENT CENTRE

M – SCHEME

(Implements from the academic year 2015-2016 onwards)

Course Name : DIPLOMA IN AGRICULTURAL TECHNOLOGY
Course Code : 1222
Subject Code : 32334
Semester : III
Subject Title : **SURVEYING AND LEVELLING**

TEACHING AND SCHEME OF EXAMINATION:

No of weeks per semester: 15 Weeks

Subject	Instruction		Examination			Duration
	Hours /week	Hours /Semesters	Marks			
			Internal Assessment	Board Examination	Total	
Surveying and levelling	5 Hrs	75 Hrs	25	75	100	3 Hrs

Topics and Allocation of Hours:

Unit No	Topic	Hours
I	Introduction - Linear measurements, Chain Surveying, and Computation of areas.	14
II	Levelling - Methods of deduction of reduced levels and Methods of levelling	13
III	Angular measurements - Compass surveying, Theodolite surveying, Trigonometrical leveling and Theodolite traversing	14
IV	Tacheometry and Contouring - Tacheometry – Contouring and Computation of volumes	13
V	Modern surveying - Total station, Global positioning system (GPS), and Geographical information system(GIS)	14
	Test and revision	7
	Total	75

RATIONALE:

The advancement of survey in the field of Agriculture in global positioning system, mapping in geographical information system and remote sensing techniques have grown to several folds. The incorporation of latest technology provides a basic foundation for the prosperity of Agricultural Technology students to become a land surveyor, proficient in handling advanced surveying instruments

OBJECTIVES:

- On completion of this module, the student should be able to:
- Understand the basic principles and scope of surveying
- Know how to use chains and tapes in taking linear measurements.
- Know the basics of leveling using dumpy level to deduce levels of points.
- Know the principal of measurement of angles using prismatic compass.
- Know the principles of measurement of angles and bearings using vernier theodolite,
and optical theodolite by trigonometrical leveling.
- Know the basics of Tacheometry and contouring.
- Know the basics of Total Station to measure angles, distances and altitudes.
- Know the basics of Global positioning system and how to locate the station with latitude and longitude observations.
- Know the basics of the Geographical information system and how to plot the map using the primary principles of mapping software.

32334 SURVEYING AND LEVELLING

DETAILED SYLLABUS

Contents: Theory

Unit	Name of the topic	Hours
I	INTRODUCTION AND LINEAR MEASUREMENTS: 1.1 Introduction: Definition, objectives-divisions of surveying (plane and geodetic)-principles of surveying; Location of a point and work from whole to the part-classification of surveying-uses. 1.2 Linear Measurements: Introduction- Chain Surveying- Types of chains-Types of tapes – Survey stations and survey lines- Types of offsets-Ranging- Direct and reciprocal ranging-chaining along a flat and slopping ground-Recording of field book with conventional signs. 1.3 Computation of an area: computation of an area of a ground with squares and triangles-computation of areas with average ordinate rule- end ordinate rule, Trapezoidal rule and Simpson's rule- problems. Computation of areas of irregular boundaries- Level section - simple problems.	14
II	LEVELLING 2.1 Introduction: Definitions- Levelling instruments, different types of levels and staves; Datum level -bench marks, types- Temporary adjustments-Line of collimation, Axis of telescope, Foresight, Back sight, Intermediate sight, Height of collimation, change point. 2.2 Methods of Reduction of levels: Methods of Reduction of levels- problems in reduction of levels by Height of collimation and rise and fall method with a minimum of two or three change points– Arithmetical check. 2.3 Methods of levelling: Methods of levelling - simple levelling, compound levelling, check levelling, Inverted levelling - Profile levelling – Longitudinal sectioning and cross sectioning- plotting the profile.	13
III	ANGULAR MEASUREMENTS 3.1 Compass surveying- The prismatic Compass: Component parts and their use; Reference meridians-magnetic and true meridian; Dip and declination; Whole circle and quadrantal bearing-Fore and back bearing - closed and open traverse-Determination of included angles- Closing error- Problem - Local attraction and its elimination; (Theory only) 3.2 Theodolite surveying: Theodolite, types-transit and non-transit-component parts of a vernier theodolite-Fundamental	14

	lines; Temporary adjustments- Measurement of horizontal angles. 3.3 Trigonometrical leveling- heights and distances- Measurement of vertical angle to determine the height and reduced level of a building, when its base is accessible and when inaccessible-simple problems.	
IV	CONTOURING, COMPUTATION OF VOLUMES AND REMOTE SENSING 4.1 Contouring -.Definitions; Contour interval and horizontal equivalent; Characteristics of contour lines- Direct and indirect methods of contouring- interpolation of contours- Use of contour maps. 4.2 Computation of volumes -Volume from contour-Trapezoidal rule- Prismoidal/ Simpson's rule-problems. Computation of volume from C.S- problems. 4.3 Remote Sensing – methods of remote sensing - remote sensing techniques for Agriculture survey.	13
V	MODERN SURVEYING 5.1 Global positioning system (GPS) -components of GPS receivers- applications/ uses- procedure for the Location of a point with its latitude and longitude – tracking a point- routing. 5.2 Geographical information system (GIS) -Components of GIS- Comparison of Ordinary mapping and with GIS software- fields of applications. 5.3 Total station -features- advantages -field procedure- to measure horizontal distances and altitudes - to measure horizontal angle and vertical angle- to fix co-ordinates.	14

Text books:

- 1) Agor R -A Text Book of Surveying And Levelling 2009, Khanna Publishers. New Delhi.
- 2) Hussain. S.K. and Nagaraj. M.S. 1992, Text Book of Surveying. S. Chand & Co. Ltd. New Delhi.
- 3) Kanetkar. R.P. and Kulkarni. S.V. 1993, Surveying and Levelling, Part-I and part-II 23rd Edition,Pune, Vaidyarthi Griha Prakashani.
- 4) Basak N N 2004,Surveying and Levelling, Tata Mcgraw -Hill Publishing co ltd. New Delhi

Reference books:

- 1) Kochher, C.I. 1993, A Text Book of Surveying. S.K. Katariya & Sons. Delhi
- Duggal S.K- A, 2006,

- 2) Text Book of Plane Surveying, second edition, fourth reprint, Tata Mcgraw -Hill Publishing co Ltd. New Delhi
- 3) Punmia P C, 2005, Surveying Volume I &II 16th edition, Laxmi publication, New Delhi.
- 4) GIS and Autocad map,2004, Prentice Hall of India Private Limited,New Delhi.
- 5) Hatfield, J.L. & Pinter, P.J.Jr. (1993). Remote sensing for crop protection (Publication No. 0261-2194/93/06/0414-09). Ames, IA: USDA - Agricultural Research Service.
- 6) Kyllö, K. P. (2003). NASA funded research on agricultural remote sensing, Department of Space Studies, University of North Dakota.



DIRECTORATE OF TECHNICAL EDUCATION

DIPLOMA IN AGRICULTURAL TECHNOLOGY

II YEAR

M SCHEME

III SEMESTER

2015-2016 (on wards)

PRINCIPLES OF CROP PRODUCTION PRACTICAL

CURRICULUM DEVELOPMENT CENTRE

M– SCHEME
(Implements from the academic year 2015-2016 onwards)

Course Name : DIPLOMA IN AGRICULTURAL TECHNOLOGY
Course Code : 1222
Subject Code : 32335
Semester : III
Subject Title : **PRINCIPLES OF CROP PRODUCTION PRACTICAL**

TEACHING AND SCHEME OF EXAMINATION:

No of weeks per semester: 15 Weeks

Subject	Instruction		Examination			Duration
	Hours /week	Hours /Semesters	Marks			
			Internal Assessment	Board Examination	Total	
Principles of Crop Production Practical	4 Hrs	60 Hrs	25	75	100	3 Hrs

RATIONALE:

The topics for practical are so designed to impart technical skills not only on the cultivation techniques but also the processing and post – harvest practices for the prescribed crops. Which will provide confidence in the minds of young agricultural technologists to become job providers rather than job seekers.

GUIDELINES:

All the sixteen experiments given in the list of experiments should be completed and given for the end semester practical examination.

In order to develop best skills in handling Instruments/Equipment and taking readings in the practical classes, every two students should be provided with a separate experimental setup for doing experiments in the laboratory.

The external examiners are requested to ensure that a single experimental question should not be given to more than four students while admitting a batch of 30 students during Board Examinations.

	ALLOCATION OF MARKS
Examination Duration : 3 Hrs	Max Marks 75
Aim	5
Observation	20
Procedure/Calculation	40
Result	5
Viva Voce	5
Total	75

32335 PRINCIPLES OF CROP PRODUCTION PRACTICAL

LIST OF EXPERIMENTS

- 1) Nursery techniques for rice
- 2) Seed treatment techniques for rice
- 3) After cultivation practices for sugarcane.
- 4) Methods of Fertilizer application to sugarcane.
- 5) Assessment of cane maturity (Brix meter).
- 6) Acid delinting in cotton.
- 7) Gypsum application and peg formation in groundnut.
- 8) Nursery management for coconut.
- 9) Planting techniques in coconut.
- 10) Fertilizer management for coconut.
- 11) Propagation techniques of mango.
- 12) Banana sucker treatment and intercultural operations.
- 13) Training and pruning in grapes.
- 14) Nursery management for chillies, tomato and bhendi.

15) Tomato seed extraction.

16) Plant growth regulators (PGR's) and their important in Horticultural crops.



DIRECTORATE OF TECHNICAL EDUCATION

DIPLOMA IN AGRICULTURAL TECHNOLOGY

II YEAR

M SCHEME

III SEMESTER

2015-2016 (on wards)

SURVEYING AND LEVELLING PRACTICAL

CURRICULUM DEVELOPMENT CENTRE

M – SCHEME

(Implements from the academic year 2015-2016 onwards)

Course Name : DIPLOMA IN AGRICULTURAL TECHNOLOGY
Course Code : 1222
Subject Code : 32336
Semester : III
Subject Title : **SURVEYING AND LEVELLING PRACTICAL**

TEACHING AND SCHEME OF EXAMINATION:

No of weeks per semester: 15 Weeks

Subject	Instruction		Examination			Duration
	Hours /week	Hours /Semesters	Marks			
			Internal Assessment	Board Examination	Total	
Surveying and leveling Practical	6 Hrs	90 Hrs	25	75	100	3 Hrs

RATIONALE:

The advancement of survey in the field of Agriculture in global positioning system, mapping in geographical information system and remote sensing techniques have grown to several folds. The incorporation of latest technology provides a basic foundation for the prosperity of Agricultural Technology students to become a land surveyor, proficient in handling advanced surveying instruments

**32336 – SURVEYING AND LEVELLING PRACTICAL
DETAILED SYLLABUS**

Content: Practical

LIST OF EXPERIMENTS AND ALLOCATION OF HOURS		
Exercises	Topic	Time (Hours)
1	PART A Chain survey Introduction –Study of chain and other accessories used in a chain survey- cross staff, arrows, ranging rod, tape, etc.,	8
2	Chaining and ranging a line and determination of area of a plot by taking perpendicular and oblique offsets.	
3	Compass survey Study of prismatic compass –Observation of bearings by conducting an open traverse	
4	Determination of Included angles in a closed clockwise traverse and apply check and detect any local attraction– minimum five points	12
5	Determination of Included angles in a closed anti-clockwise traverse and apply check and detect any local attraction–minimum five points.	
6	Distance between any two points when their base is accessible	
7	Theodolite survey Study of vernier theodolite and Temporary adjustments.	
8	Measurement of horizontal angle by repetition/ reiteration method.	12
9	Measurement of vertical angle .	
10	PART B Levelling Study of level –Temporary adjustments-simple levelling	
11	Fly levelling –Inclusive of an inverted level reading- Reduction of levels by Height of collimation method- minimum six points (inclusive of two change points).	
12	Fly levelling – Inclusive of an inverted level reading - Reduction of levels by Rise and fall method-minimum six points (inclusive of two change points)	16
13	Check levelling and reduction of levels.	
14	Longitudinal sectioning and cross sectioning of a canal embankment or Road alignment.	

PART C		
15	Total station Study of Total station –determination of horizontal distance and angle between two points and reduced level of those points	4
Global positioning system -GPS		
16	Determination of location of a point with latitude and longitude observations using a hand held GPS receiver	4
	Test and Revision	4
	Total	60

Allocation of Marks.

Sl. No	Item	Part A	Part B	Part C
1	Aim, Procedure, and Formula	4	8	2
2	Figure/Circuit Diagram	4	8	2
3	Tabulation	4	8	2
4	Observation	4	8	2
5	Calculation and Result	4	8	2
	Total	20	40	10
6	Viva-voce	5		
	Total	75		

LIST OF EQUIPMENTS AND THE QUANTITY REQUIRED FOR A BATCH OF 30 STUDENTS

1.	Metric chain (30m)	-5Nos
2.	Metric chain (20m)	-5 Nos
3.	Metallic tape (30m)	-5 Nos
4.	Metallic tape (15m)	-5 Nos
5.	Cross staff (wooden)	-10 Nos
6.	Ranging rod	-50 Nos
7.	Arrow	-100 Nos
8.	Wooden peg	-50 Nos
9.	Levelling instrument (Dumpy level)	-15 Nos
10.	Levelling staff(aluminium body 4m long-Telescopic)	-10 Nos
11.	Levelling staff wooden (4m-Telescopic)	-5 Nos
12.	Vernier theodolite/micrometer theodolite	-10 Nos
13.	Total station	-1 No (Min)
14.	GPS receiver	-2 Nos

SAFETY PRECAUTIONS TO BE FOLLOWED

1. Handle the ranging rod with care while moving among the public as the sharp end may harm.
2. Handle all the electronic equipments with extra care.
3. Batteries after use should be removed from the equipment to prevent leakage.



DIRECTORATE OF TECHNICAL EDUCATION

DIPLOMA IN AGRICULTURAL TECHNOLOGY

II YEAR

M SCHEME

III SEMESTER

2015-2016 (on wards)

COMPUTER APPLICATION PRACTICAL

CURRICULUM DEVELOPMENT CENTRE

STATE BOARD OF TECHNICAL EDUCATION & TRAINING, TAMILNADU.

DIPLOMA IN COMPUTER ENGINEERING

M- SCHEME

(to be implemented for the student Admitted from the Year 2015-2016 on wards)

(Implemented from the academic year 2016-2017 onwards)

Course Name : For All Branches

Subject Code : 30001

Semester : III

Subject title : COMPUTER APPLICATIONS PRACTICAL

TEACHING & SCHEME OF EXAMINATION:

No. of weeks per Semester: 15 Weeks

Course	Instruction		Examination			Duration
			Max.			
	Hours/ week	Hours/ Semester	Internal Assessment	Board Examination	Total	
COMPUTER APPLICATIONS PRACTICAL	4Hrs	60 Hrs	25	75	100	3Hrs

RATIONALE:

The application of Computer knowledge is essential the students of all disciplines of Engineering in addition to their respective branch of study. The Computer Application Practical course facilitates the necessary knowledge and skills regarding creating, working and maintaining the documents and presentation of documents with audio visual effects in a computer and produces necessary skills in E- Learning and Chatting tools..

OBJECTIVES:

On completion of the following exercises, the students will be able to

- Use the GUI operating systems
- Familiarize and customize the desktop
- Use the different facilities available in the word processor
- Prepare Power Point presentation with different formats
- Expose E-learning tools and chatting tools
- Analyze the datasheet
- Create and manipulate the database
- Create different types of charts
- Prepare PowerPoint presentation
- Understand Internet concepts and usage of e-mail

GUIDELINES:

- All the experiments given in the list of experiments should be completed and all the experiments should include for the end semester practical examination.
- The computer systems should be 1:1 ratio for practical classes

**SYLLABUS
LAB EXERCISES
SECTION – A**

GRAPHICAL OPERATING SYSTEM

Introduction to GUI OS; Features and various versions of GUI OS & its use; Working with GUI OS; My Computer & Recycle bin ; Desktop, Icons and Explorer; Screen description & working styles of GUI OS; Dialog Boxes & Toolbars; Working with Files & Folders; simple operations like copy, delete, moving of files and folders from one drive to another, Shortcuts & Autostart; Accessories and Windows Settings using Control Panel- setting common devices using control panel, modem, printers, audio, network, fonts, creating users, internet settings, Start button & Program lists; Installing and Uninstalling new Hard ware & Software program on your computer - Copying in CD/DVD settings – Recording Audio files.

Exercises

1. a. Installing screen saver and change the monitor resolution by 1280X960
b. Setting wall papers
c. Creating, moving, deleting and renaming a folder
d. Copy, paste and cut a folder/file
e. Displaying the properties for a file or folder
2. a. Restoring files and folders from Recycle bin
b. Creating short cuts for folder/file
c. Finding a file or folder by name
d. Selecting and moving two or more files/folders using mouse
e. Sorting folders/files.

WORD PROCESSING

Introduction to Word Processing – Examples- Creation of new documents, opening document, insert a document into another document. Page setup, margins, gutters, font properties, Alignment, page breaks, header footer deleting, moving, replace, editing text in document. Saving a document, spell checker.

Printing a document. Creating a table, entering and editing, Text in tables. Changing format of table, height width of row or column. Editing, deleting Rows, columns in table. Borders, shading, Templates, wizards, drawing objects, mail merge.

Exercises

3. Create the following table and perform the operations given below

DAYS	1	2	3	4	5	6	7	8
MON	←TEST→		A: JPP			CA	RDBMS	TUT
	B:RDBMS							
TUE	CA	OOP	CN	RDBMS	A: RDBMS			
	B: JPP							
WED	CN	RDBMS	OOP	RDBMS	COMMUNICATIO N	CN	CA	
THU	OOP	A: JPP			CA	RDBMS	CN	OOP
		B: RDBMS						
FRI	COMMUNICATI ON		A: RDBMS		OOP	CN	RDBMS	CA
			B: JPP					
SAT	OOPS	RDBMS	CN	CA	-----			

4. Create a standard covering letter and use mail merge to generate the customized letters for applying to a job in various organizations. Also, create a database and generate labels for the applying organizations.
5. Create a news letter of three pages with two columns text. The first page contains some formatting bullets and numbers. Set the document background colour and add 'confidential' as the watermark. Give the document a title which should be displayed in the header. The header/footer of the first page should be different from other two pages. Also, add author name and date/time in the header. The footer should have the page number.

SPREADSHEET

Introduction to Analysis Package – Examples - Concepts of Workbook & Worksheets; Using Wizards; Various Data Types; Using different features with Data, Cell and Texts; Inserting, Removing & Resizing of Columns & Rows; Working with Data & Ranges; Different Views of Worksheets; Column Freezing, Labels, Hiding, Splitting etc.; Using different features with Data and Text; Use of Formulas, Calculations & Functions; Cell Formatting including Borders & Shading; Working with Different Chart Types; Printing of Workbook & Worksheets with various options.

Exercises

6. Create a result sheet containing Candidate's Register No., Name, Marks for six subjects. Calculate the total and result. The result must be calculated as below and failed candidates should be turned to red.

Result is Distinction if Total $\geq 70\%$

First Class if Total $> 60\%$ and $< 70\%$

Second Class if Total $\geq 50\%$ and $< 60\%$

Pass if Total $\geq 35\%$ and $< 50\%$

Fail otherwise

Create a separate table based on class by using auto filter feature.

7. Create a table of records with columns as Name and Donation Amount. Donation amount should be formatted with two decimal places. There should be at least twenty records in the table. Create a conditional format to highlight the highest donation with blue color and lowest donation with red colour. The table should have a heading.
8. Create line and bar chart to highlight the sales of the company for three different periods for the following data.

SALES BAR CHART

Period	Product1	Product2	Product3	Total
JAN	35	40	50	125
FEB	46	56	40	142
MAR	70	50	40	160

SECTION – B

DATABASE

Introduction – Menus – Tool bar – Create – Edit – Save – Data types – Insert – Delete – Update – View – Sorting and filtering – Queries – Report – Page setup – Print.

Exercises

9. Create Database to maintain at least 10 addresses of your class mates with the following constraints

- Roll no. should be the primary key.
- Name should be not null

10. create a students table with the following fields: Sr.No, Reg. No, Name, Marks in 5 subjects. Calculate total and percentage of 10 students. Perform the following queries.

- To find the details of distinction student
- To find the details of first class students
- To find the details of second class students

11. Design a report for the above exercise to print the consolidated result sheet and mark card for the student.

PRESENTATION

Introduction - Opening new presentation, Parts of PowerPoint window – Opening -Saving and closing presentations - Features of PowerPoint, Background design, Word art, Clip art, Drawings,3D settings - Animations, Sound, Views, types of views - Inserting and deleting slides, arranging slides, slides show, rehearsal, setup show, custom show - Creating custom presentations, action setting, auto content wizard, working with auto content wizard

Exercises

12. Make a marketing presentation of any consumer product with at least 10 slides.
Use different customized animation effects on pictures and clip art on any four of the ten slides.
13. Create a Presentation about our institution or any subject with different slide transition with sound effect.

INTERNET

Introduction – Getting acquainted with Internet Connection - Browsers – Website URL - Open a website – Net Browsing - Email: Creating E-mail id – Sending , receiving and deleting E-mail - Email with Attachments – CC and BCC - Chatting – Creating Group mail - Google docs – Search Engines – Searching topics .

Most Popular Social Networking Sites : History – Features – Services – Usage of Face book , Twitter and LinkdIn.

Transferring data through wifi / bluetooth among different devices.

Introduction to cybercrime – Software Piracy – Viruses – Antivirus Software

Exercises

14. Create an e-mail id and perform the following
 - Write an e-mail inviting your friends to your Birthday Party.
 - Make your own signature and add it to the e-mail message.
 - Add a word attachment of the venue route
 - Send the e-mail to at least 5 of your friends.

15. Create a presentation on Google docs. Ask your friend to review it and comment on it. Use “Discussion” option for your discussions on the presentation.

Hardware and Software Requirements

Hardware Requirements:

- Computers – 36Nos
 - Intel Core i3 Processor
 - 500 GB Hard Disk, 2 MB RAM
 - 14” Monitor
- Projector – 1 Nos
- Laser Printer – 1 No
- Internet Connection – Minimum of 512 KB

Software Requirement

- Any GUI Operating System
- Open Source Software / MS- Office

1. SemesterEndExamination–75 Marks

Content	Max.Marks
Writing Procedure – One Question from Section A	15
Demonstration	15
Results with Printout	5
Writing Procedure – One Question from Section B	15
Demonstration	15
Results with Printout	5
Viva voce	5
Total	75MARK

IV SEMESTER



DIRECTORATE OF TECHNICAL EDUCATION

DIPLOMA IN AGRICULTURAL TECHNOLOGY

II YEAR

M SCHEME

IV SEMESTER

2015-2016 (on wards)

FLUID MECHANICS

CURRICULUM DEVELOPMENT CENTRE

M – SCHEME

(Implements from the academic year 2015-2016 onwards)

Course Name : DIPLOMA IN AGRICULTURAL TECHNOLOGY
Course Code : 1222
Subject Code : 32341
Semester : IV
Subject Title : **FLUID MECHANICS**

TEACHING AND SCHEME OF EXAMINATION:

No of weeks per semester: 15 Weeks

Subject	Instruction		Examination			Duration
	Hours /week	Hours /Semesters	Marks			
			Internal Assessment	Board Examination	Total	
Fluid Mechanics	6 Hrs	90 Hrs	25	75	100	3 Hrs

Topics and Allocation of Hours:

Unit No	Topic	Time (Hrs)
I	Properties of fluids, pressure and its measurement	16
II	Flow of fluids	17
III	Flow through pipes and open channels	16
IV	Pneumatic & hydraulic system	17
V	Agricultural pumps	17
	Revision and test	7
	Total	90

RATIONALE:

Now a days the fluid mechanics find wide applications in many situations directly or indirectly. Agricultural engineers are expected to have the knowledge and the understanding of the basic principles and concepts of fluid mechanics both in static and dynamic conditions. This is to enable them to analyze and design systems in which fluid is the working medium.

OBJECTIVES:

- To understand the various properties of fluids. Explain the working of mechanical gauges.
- Explain continuity equation and Bernoulli's equation. Know types of flow of fluids and practical applications.
- Estimate the discharge through orifices, mouth pieces, notches & weirs.
- Definition of flow through pipes, losses of head due to friction.
- Flow through open channel, velocity of flow in open channel.
- Assess the Impact of Jets on a stationary flat plate held normal and inclined. Classifications of Hydraulic Turbines, types of draft tubes functions.
- Explain the working of Centrifugal pumps Reciprocating Pumps

**IV SEMESTER AGRICULTURAL TECHNOLOGY
32341 FLUID MECHANICS
DETAILED SYLLABUS**

Content: Theory

Unit	Name of topic	Hours
I	<p>1.1 PROPERTIES OF FLUIDS Definition-fluid mechanics, fluids- types-Properties of fluids – mass, weight, mass density, weight density, specific volume, specific gravity, compressibility, vapour pressure, cohesion and adhesion, surface tension, capillarity, viscosity, kinematic viscosity – classification of fluids –Problems.</p> <p>1.2 PRESSURE AND ITS MEASUREMENT Pressure units – atmospheric pressure – gauge pressure – vacuum pressure –absolute pressure – pressure vary with depth and pressure head – pressure head in terms of equivalent liquid column – Pascal’s law of transmissibility –applications – Pressure device –Piezometer tubes – U-tube manometers (simple and differential) problems. Mechanical pressure gauges: Bourdon’s tube, diaphragm and dead weight pressure gauges. Pressure on plane surfaces – Total pressure – centre of pressure – depth of centre of pressure – fluid pressure on plane surfaces immerse in liquid, vertically and inclined – simple problems.</p>	16
II	<p>2.1 FLOW OF FLUIDS Types of fluid flow – steady, unsteady – uniform and non-uniform – laminar, turbulent, definitions only – mean velocity of flow- principles of fluid flow- discharge of a flowing fluid, units – Equation of continuity of flow – Energies of fluid- Hydraulic energy and total head – Bernoulli’s theorem (statement only) – limitations – practical applications – problems –Venturimeter – simple problems – Orifice meter – comparison with Venturimeter – Pitot – simple problems.</p> <p>2.2 ORIFICES, MOUTH PIECES, NOTCHES & WEIRS Orifice – definition – classification of orifices – Flow through small orifice – head causing flow –Jet- Vena-contracta – velocity and discharge through an orifice – hydraulic coefficients and its relationship – problems – Large rectangular orifice- Discharge through large rectangular orifice- derivation- simple problems- Mouth piece - definition – types – Notches – definition – types – discharge through rectangular & triangular notches – derivations-</p>	17

	Advantages of V-notch over rectangular notch – simple problems– Weir –classification – difference between notch and weir.	
III	<p>3.1 FLOW THROUGH PIPES Definition of pipe – Critical velocity – Reynold’s number – hydraulic gradient line and total energy line – definitions – wetted perimeter – hydraulic radius – losses in pipes – Major losses – minor losses- loss of head due to friction in pipe line – Darcy-Weisbach equation derivation– Chezy’s equation derivation – loss of head due to sudden enlargement – sudden contraction – entry in to a pipe – exit from a pipe – an obstruction – change in direction (only formulae for minor loses)– power transmission through pipes – maximum power – efficiency of transmission – simple problems.</p> <p>3.2 OPEN CHANNELS Flow through open channels: Open channel – definition & types – Types of flow in open channel – wetted perimeter, hydraulic mean depth and hydraulic slope –Chezy’s formula for velocity of flow in open channel – value of Chezy’s constant– Basin’s formula, Kutter’s formula and Manning’s formula – problems. Economical section of rectangular channel- derivation and problems – Venturiflume.</p>	16
IV	<p>4.PNEUMATIC & HYDRAULIC SYSTEM</p> <p>4.1 Pneumatic system: Introduction – elements of pneumatic system- air filters-pressure regulator- lubricator- air service unit (FRL package)- pneumatic valves- pressure control valves- pressure relief (limiting)- direction control valves- classifications- check valves- 2/2DCV- 3/2DCV- 4/2DCV- 4/3DCV- pneumatic circuits- single acting cylinder- double acting cylinder-metering-in control and metering-out control.</p> <p>4.2 Hydraulic system: Introduction – elements of hydraulic system- Advantages and disadvantages of hydraulic system- Hydraulic accumulators- types- weighted – spring loaded- gas operated- bladder – fluid power pumps- types-gear pump- vane pump- hydraulic actuators- single acting cylinder- double acting cylinder- gear type and vane type- hydraulic valves- pressure control valves- pressure relief valves- pressure reducing valves- flow control valve- globe valve- needle valve- gate valve- direction control valve- types. Meter-in and meter-out circuits- pneumatic system vs hydraulic system.</p>	17

V	<p>5.1 CENTRIFUGAL PUMPS Centrifugal pumps –classifications- description and working – Types of casings and impellers – operation of centrifugal pumps – priming – use of foot valve and strainers –Layout and accessories – Maximum height of suction – Multistage pumps – Maintenance and repair of centrifugal pumps – Simple Problems on discharge, power and efficiency – Criteria for selection of pump – no problems.</p> <p>5.2 RECIPROCATING PUMPS Reciprocating pumps – classifications – working of single acting and double acting reciprocating pump – plunger and piston pumps – discharge of reciprocating pump – theoretical power required – coefficient of discharge – slip – negative slip – separation or cavitations – air vessel –simple problems. Special pumps – jet pumps – Turbine pumps – Submersible pumps – Working principles – no problems. Hydraulic power plant – turbines-definition - classification of turbines.</p>	17
----------	---	----

Reference books:

1. Hydraulics and fluid Mechanics – E.H. Lewitt
2. Hydraulics, Fluid Mechanics and Hydraulic Machines – R.S. Khurmi
3. Fluid mechanics – Bansal.



DIRECTORATE OF TECHNICAL EDUCATION

DIPLOMA IN AGRICULTURAL TECHNOLOGY

II YEAR

M SCHEME

IV SEMESTER

2015-2016 (on wards)

SOIL & WATER CONSERVATION ENGINEERING

CURRICULUM DEVELOPMENT CENTRE

M – SCHEME

(Implements from the academic year 2015-2016 onwards)

Course Name : DIPLOMA IN AGRICULTURAL TECHNOLOGY
Course Code : 1222
Subject Code : 32342
Semester : IV
Subject Title : **SOIL & WATER CONSERVATION ENGINEERING**

TEACHING AND SCHEME OF EXAMINATION:

No of weeks per semester: 15 Weeks

Subject	Instruction		Examination			Duration
	Hours /week	Hours /Semester	Marks			
			Internal Assessment	Board Examination	Total	
SOIL & WATER CONSERVATION ENGINEERING	5 Hrs	75 Hrs	25	75	100	3 Hrs

Topics and Allocation of Hours:

Unit No	Topic	Time (Hrs)
I	Introduction & Mechanism of Erosion	14
II	Wind Erosion	13
III	Field Structures to Control Erosion	14
IV	Gully Erosion	13
V	Permanent Gully control structure	14
	Test & revision	7
	Total	75

RATIONALE:

Soil and Water Conservation engineering is one of the basic subject in the field of Agricultural engineering. Since the main focus of agricultural engineering is production maximization, Soil and water conservation is the major area where these resources are basic and important for Crop Production.

Evil effects of soil erosion should be understood clearly then only the suitable conservation measures may be found out.

OBJECTIVES:

- To study history and problems of soil erosion Soil conservatory methods
- To study on factors affecting soil erosion To study development of Gullies
- To study on ravine reclamation and Gully control structures To study on wind erosion and its forms
- To study on Agronomical practice to control erosion To study on water harvesting techniques
- To study on farm ponds, percolation ponds

32342 SOIL & WATER CONSERVATION ENGINEERING

DETAILED SYLLABUS

Contents : Theory

Unit	Name of the topic	Hours
I	<p>Introduction & Mechanism of Erosion</p> <p>Introduction – Principle factors responsible for Soil loss – Soil erosion (Definition) – History of soil erosion – Hydrological soil group – special soil conservation problem – Types of soil erosion – factors affecting Erosion by water - Types of water erosion and their effects – Principles of gully erosion – Four stages of Gully development – classification of Gullies.</p> <p>Hydrology of small water sheds – rainfall- Gauging of Rainfall – Runoff – rational Method of prediction of Runoff Rate – Runoff Hydrograph – simple Problems.</p>	14 Hrs
II	<p>Wind Erosion</p> <p>Wind Erosion and its control – soil movement by wind – Sand dunes – Threshold velocity – Factors influencing Soil Erodibility by wind – Estimating Soil erosion by wind – Measures to Control Soil Erosion By Wind – Vegetation and Vegetative Management – Tillage Practices and Machinery to Control Soil Blowing – Surface Roughness – Wind Breaks and shelter belts.</p>	13 Hrs
III	<p>Field Structures to Control Erosion</p> <p>Field structures and Practices to Control erosion by water – Land use Capability - Classification and Land use planning – Contouring – Strip cropping – conservation Tillage – Contour Trenching – Types of Terraces – Graded Bunds – Bench Terraces Types – Contour Bunding – Construction of contour Bunds – Vegetated Water ways – Forestry in soil conservation.</p>	14Hrs
IV	<p>Gully Erosion</p> <p>Gully Control and Ravine Reclamation Definition – Gully – Gully Erosion planning – Gully Control – Controlling Runoff – Vegetation in Gully Control – Changing Gullies into Grassed Water ways and Establishment of sod Flumes – Sod Checks and shrub Checks – Checking the Growth of Gullies – Gully Control Procedure – Gully Control Structures – Temporary Check Dams – Woven Wire Dams – Brush dams – loose rock dams – plank or slab dams – log and pole dams.</p>	13 Hrs

V	<p>Permanent Gully control structure</p> <p>Permanent Structures for soil conservation and Gully control – purpose – Basic components of soil conservation and Gully Control Structures – Check dams – Drop Spill Ways – Inlet – Outlet – Chute Spill ways – Inlet- Channel section – Outlet – Drop inlet Spillway.</p>	14 Hrs
----------	--	---------------

Reference Book :

1. Principles of Agricultural Engineering A.M. Michael, T.P. Ojah.
2. Soil and water conservation Engineering R. Suresh – Standard publishers Distributors 1705 B.Nai sarak, New Delhi – 110 006.



DIRECTORATE OF TECHNICAL EDUCATION

DIPLOMA IN AGRICULTURAL TECHNOLOGY

II YEAR

M SCHEME

IV SEMESTER

2015-2016 (on wards)

IRRIGATION ENGINEERING

CURRICULUM DEVELOPMENT CENTRE

M – SCHEME

(Implements from the academic year 2015-2016 onwards)

Course Name : DIPLOMA IN AGRICULTURAL TECHNOLOGY
Course Code : 1222
Subject Code : 32343
Semester : IV
Subject Title : **IRRIGATION ENGINEERING**

TEACHING AND SCHEME OF EXAMINATION:

No of weeks per semester: 15 Weeks

Subject	Instruction		Examination			Duration
	Hours /week	Hours /Semester	Marks			
Irrigation Engineering	5 Hrs	75 Hrs	Internal Assessment	Board Examination	Total	3 Hrs
			25	75	100	

Topics and Allocation of Hours:

Unit No	Topic	Time (Hrs)
I	Irrigation techniques and quality of irrigation water	16
II	Canal Irrigation system	13
III	Hydrology, ground water exploration and soil plant water relationship	13
IV	Water application methods	13
V	Water logging and land drainage	13
	Revision and test	7
	Total	75

RATIONALE:

Water is a scarce commodity in the universe. Universe without water is not a place to live. One cannot grow crops without water. The water use efficiency is the main point in sharing river water across the countries. Judicial and efficient use of water becomes vital for the longevity of our mother earth.

This subject Irrigation Engineering aims to study about the sources of water and methods of water use effectively.

OBJECTIVES:

- To understand the basic of Irrigation engineering
- To understand the methods of irrigation and water quality.
- To know about the irrigation methods and sources of irrigation.
- To know about the plant-water- soil relationship.
- To understand about ground water and other water sources.
- To understand about application rate.
- To understand about water logging and drainage in land use.

32343 IRRIGATION ENGINEERING
DETAILED SYLLABUS

Contents : Theory

UNITS	NAME OF TOPIC	HOURS
I	<p>Irrigation techniques and quality of irrigation water: Definition –Advantages and Disadvantages of irrigation – Types of Irrigation – Irrigation methods - Surface and subsurface Irrigation -Free flooding-Border flooding-Check flooding-Basin flooding- Furrow irrigation- Drip irrigation- Sprinkler Irrigation Methods.</p> <p>Crop water requirement – Crop period or Base period – Duty and delta – Duty of water – Relationship between Duty and Delta – factors affecting duty – Importance of duty. Duty for certain Crops. Crop seasons – Crop Ratio - optimum utilization of Irrigation water – Irrigation efficiency- Consumptive Use or Evapo-transpiration (Cu)- Consumptive Irrigation Requirement(CIR), Net Irrigation Requirement(NIR), Factors affecting consumptive use-Estimation of consumptive use-Blaney-Criddle Formula-Hargreaves class A pan evaporation method- Soil-moisture-Irrigation Relationship-Field Capacity-Permanent wilting point-available moisture-Readily available moisture-Soil moisture deficiency-Equivalent moisture.</p>	16
II	<p>Canal Irrigation system: Alluvial and non – alluvial soils - Alignment of canals – water shed canal – contour canal – side slope canal – Distribution system for canal Irrigation – Gross command area – cultivable command area – Intensity of Irrigation. Area to be Irrigated. Determination of required channel capacity - channel losses. Evaporation and seepage - lining of Irrigation canals – Advantages of lining – construction of a various types of lining.</p>	13
III	<p>Hydrology, ground water exploration and soil plant water relationship: Definition – Hydrologic cycle - Aquifers – Types – unconfined – confined – perched – infiltration wells – Artificial underground storage – methods of recharging – spreading method - Recharge well method - Wells and their construction - Open wells and tube wells - Yields of an open well – Pumping test – Recuperation test – Tube wells – various types of tube wells – Types of pumping – Centrifugal pumping – Bore hole pumping - Measurement of irrigation water – Methods - weirs – Parshal flumes – Orifices – soil, plant, water relationship – Water relations on soil – Soil moisture and plant growth.</p>	13

IV	<p>Water application methods :</p> <p>Border irrigation – check Basin Irrigation – Furrow irrigation – Drip irrigation – Components – Pump, Motor, Filters, Main, Sub-main, Laterals, fertigation – Booster systems – Sprinkler irrigation system – Various types – Advantages and limitations – Components – Fertilizer applications – Moisture distribution pattern and uniformity of coverage – design of sprinkler irrigation system – operation and maintenance.</p>	13
V	<p>Water logging and land drainage:</p> <p>Distribution and effects – Causes of water logging – Water Logging control – Reclamation of saline lands – Land drainage – Surface drainage – Sub-surface drainage – Surface inlets – French drains Bedding – Sub surface drainage or Tile drainage.</p>	13

Reference Books

1. Irrigation Engineering and Hydraulic Structures
Santhosh Kumar Garg, Khanna publishers - Delhi 110 006.
2. Irrigation Theory and Practice - A.M. Michael, Director (Retd.)
Indian Agricultural Research Institute, Vikas Publishing house Pvt. Ltd.
3. Principles and Practice of Irrigation Engineering- S.K.SHARMA
S.Chand &Company Ltd, Ram nagar, New Delhi-110055.



DIRECTORATE OF TECHNICAL EDUCATION

DIPLOMA IN AGRICULTURAL TECHNOLOGY

II YEAR

M SCHEME

IV SEMESTER

2015-2016(on wards)

ELECTRICAL DRIVES AND CONTROL

CURRICULUM DEVELOPMENT CENTRE

M-SCHEME

(Implements from the Academic year 2015-2016 onwards)

Course Name : DIPLOMA IN AGRICULTURAL TECHNOLOGY
Course Code : 1222
Subject Code : 32044
Semester : IV
Subject Title : ELECTRICAL DRIVES AND CONTROL

TEACHING AND SCHEME OF EXAMINATIONS:

No. of Weeks per Semester: 15 Weeks

Subject	Instructions		Examination			Duration
	Hours /Week	Hours/ Semester	Marks			
Electrical Drives and Control	6	90	Internal Assessment	Board Examination	Total	3 Hrs
			25	75	100	

Topics and Allocation of Hours:

Unit	Topics	Hours
I	DC CIRCUITS AND DC MACHINES	17
II	AC CIRCUITS AND AC MACHINES	17
III	STEPPER AND SERVO MOTORS & DRIVES	17
IV	POWER SUPPLIES AND LOGIC GATES	16
V	CONTROL ELEMENTS AND PLC	16
	TEST AND REVISION	7
	Total	90

RATIONALE:

The automation is being the order of the day to improve the production with high quality consciousness. Such automation involves electrically operated switches, sensors controlled through electrically driven motors and actuators. The subject aims in introducing the basic electrical DC and AC circuits and motors and also focuses on the various special control devices like stepper, servo drives and its controlling elements.

OBJECTIVES:

- Explore fundamental electric circuit laws.
- Explain the working principle of DC and AC Electrical machines.
- Identify the effective uses of drives of Electrical machines.
- Analyze the various power supply circuits.
- Select the field controlled elements.
- Explain the construction and working of Transformer.
- Compare the different types of Logic gates.
- Appreciate the safety practices followed in Electrical system.
- Compare the use of servo motors and stepper motors in electrical driving system
- Identify PLC Input outputs.
- Identify the use of Control elements.

32044 ELECTRICAL DRIVES & CONTROL
DETAILED SYLLABUS

Contents: Theory

Unit	Name of the Topic	Hours
I	<p>DC CIRCUITS AND DC MACHINES</p> <p>Definition- Electric current, voltage and resistance -Ohm's law and Kirchoff's law. Resistance in series and parallel and series, parallel – simple problems electromagnetism(definitions only) – magnetic flux, flux density magnetic field intensity, MMF, permeability, reluctance, Faraday's law of electromagnetic induction, electrical and mechanical units</p> <p>DC generators – construction, principle of operation, types and application.</p> <p>DC motors: - construction, principle of operation, types and application.</p> <p>Necessity of starters: Three point, four point starters.</p>	17
II	<p>AC CIRCUITS AND AC MACHINES</p> <p>Fundamentals of AC voltage, and current – peak, average, RMS value of sine wave, frequency, time period, amplitude, power and power factor (definition only)- star and delta connection relationship between phase, line voltage and current in star and delta connections.</p> <p>Transformer: Principle of operation and construction – EMF equation (no definition)- losses in Transformer – efficiency – application.</p> <p>Alternator construction – principle of operation – types and applications.</p> <p>AC machine: AC motors- Principle of operation of single phase capacitor start and universal motor induction motor- applications- Three phase induction motors – Squirrel cage and slip ring Induction motors (construction and working principle only) - application – speed control of 3Φ Induction motor -Necessity of starters – DOL and star/delta starter.</p>	17

<p>III</p>	<p>STEPPER AND SERVO MOTORS & DRIVES:</p> <p>PMDC, Stepper motor- construction and working principle and applications - Servo motor – types: brushless servo motor, permanent magnet servo motor construction and applications.</p> <p>Industrial drives- types, group drive, individual drive, multi motor drive, block diagram of Variable frequency drive , stepper motor drive: single stepping and half stepping. Servo drives.</p> <p>Electrical safety: - importance of earthing - electric shock: first aid, precautions - causes of accident and their preventive measures.</p> <p>Energy conservation</p>	<p>17</p>
<p>IV</p>	<p>POWER SUPPLIES AND LOGIC GATES</p> <p>Diode – terminals: anode and cathode, forward biasing and reverse biasing – use of diode in rectifiers – half wave and full wave – necessity of filters- Regulated power supplies: IC voltage regulators – SMPS, UPS and Inverters – General description and their applications.</p> <p>Display devices – LED, 7 segment LED, LCD</p> <p>Logic gates: Positive and negative logic, definition, symbol truth table, Boolean expression for OR, AND, NOT, NOR, NAND, EXOR and EXNOR gates – Universal logic Gates: NAND, and NOR.</p>	<p>16</p>
<p>V</p>	<p>CONTROL ELEMENTS AND PLC</p> <p>Fuses – selection of fuse – necessity of fuse- fuse switch units.</p> <p>Sensors: Photo electric sensor, Inductive proximity sensors, Temperature sensors.</p> <p>Switches: Push button switch, selector switch, limit switch, pressure switch, temperature switch, float switch and reed switch.</p> <p>Relays – NO, NC – usage- bimetallic thermal overload relays.</p> <p>Contactors- usage – necessity of contactor- Solenoid type contactor</p> <p>Circuit breakers – Miniature case Circuit breaker (MCCB) and Miniature Circuit breaker (MCB), Oil Circuit breakers (OCB), Earth leakage circuit breaker (ELCB) Features of PLC-PLC Block diagram- PLC scan - Fixed and modular PLC Ladder logic-NO, NC contacts- Coils-AND, OR.</p>	<p>16</p>

Text Books:

- 1) A course in electrical engineering - B.L.Theraja - Multi Colour Edition, S Chand & Co, Reprint 2006
- 2) Control of Machines - S.K Bhattacharya, Brijinder Singh – New Age Publishers, Second Edition- Reprint 2010
- 3) Electronic Circuits & System- Analog and Digital – Y.N.Bapat - Tata Mc Graw Hill.

Reference Books:

- 1) Electrical Technology – Hughes - 8th Edition, Pearson Education.
- 2) Electronic Device and Circuits- An introduction – Allen Mottershed - Prentice Hall of India.



DIRECTORATE OF TECHNICAL EDUCATION

DIPLOMA IN AGRICULTURAL TECHNOLOGY

II YEAR

M SCHEME

IV SEMESTER

2015-2016 (on wards)

MECHANICAL TESTING & FLUID POWER PRACTICAL

CURRICULUM DEVELOPMENT CENTRE

M- SCHEME

(Implements from the academic year 2015-2016 onwards)

Course Name : DIPLOMA IN AGRICULTURAL TECHNOLOGY
Course Code : 1222
Subject Code : 32345
Semester : IV
Subject Title : **MECHANICAL TESTING & FLUID POWER PRACTICAL**

TEACHING AND SCHEME OF EXAMINATION:

No of weeks per semester: 15 Weeks

Subject	Instruction		Examination			Duration
	Hours /week	Hours /Semester	Marks			
Mechanical Testing & Fluid Power Practical	4 Hrs	60 Hrs	Internal Assessment	Board Examination	Total	3 Hrs
			25	75	100	

RATIONALE:

The modern advancement in the field of Mechanical testing of materials and fluid power can be well effected only when on hand experience is imparted to the students. The quality of materials used and the advantages of hydraulic power, fluid power and pneumatic power can be well understood by the students only in the practical classes.

GUIDELINES/ SPECIFIC INSTRUCTIONS:

All the sixteen experiments have to be completed before the end of the semester.

Every two students have to be provided on hand experience separately in handling and conducting the experiments.

External Examiner is requested to ensure 100% of the experiments are completed and also that a single experimental question is not repeated for not more than four students in a batch of 30 students.

**BOARD EXAMINATION
ALLOCATION OF MARKS**

Sl. No	Item	Mechanical Testing Practical	Fluid Power practical
1	Aim, Procedure, and Formula	7	7
2	Figure/Circuit Diagram	4	4
3	Tabulation	7	7
4	Observation	7	7
5	Calculation and Result	10	10
	Total	35	35
6	Viva-voce		5
	Total		75

32345 MECHANICAL TESTING & FLUID POWER PRACTICAL

LIST OF EXPERIMENTS AND ALLOCATION OF HOURS		
Exercises	Topics	Hours
	Mechanical Testing	
1	Determine the yield stress, ultimate stress, breaking stress, working stress, percentage of elongation and percentage of reduction for materials like mild steel/TMT bars by conducting tension test using universal testing machine.	20
2	Determine the deflection and young's modulus of mild steel/hollow circular simply supported section by applying a point load at the center.	
3	Determine the shear strength of various materials like steel/mild steel/ TMT bars by conducting shear test using universal testing machine.	
4	Determine the modulus of rigidity by performing torsion test on mild steel specimen.	
5	Determine the specific impact energy by conducting Izod impact test on materials like mild steel, cast iron, copper etc.,	
6	Determine the Brinell/Rockwell hardness number by conducting hardness test on materials like mild steel, cast iron, copper etc.,	
7	Determine the modulus of rigidity on the closed coil spring of mild steel specimen.	
	Fluid Power	
8	Determine the coefficient of discharge through flow measuring devices like orifice by variable head method	24
9	Determine the coefficient of discharge through flow measuring devices like mouth piece by variable head method	
10	Determine the coefficient of discharge through flow measuring devices like orifice by constant head method	
11	Determine the coefficient of discharge through flow measuring devices like mouth piece by constant head method.	
12	Verification of Bernoulli's Theorem.	
13	Determine the coefficient of discharge through flow measuring devices like venture-meter.	

14	Determine the coefficient of discharge through flow measuring devices like orifice meter.	
15	Determine the friction factor in 'flow through pipes'.	
	Pumps :	
16	Conduct performance test on Centrifugal pump.	12
17	Conduct performance test on reciprocating pump.	
18	Make suitable pneumatic circuit of metering in or metering out connection using the double acting reciprocating cylinder with flow regulator, control valve and check valve.	
	Test and Revision	4
	Total	60

LIST OF EQUIPMENTS AND THE QUANTITY REQUIRED FOR A BATCH OF 30 STUDENTS:

Mechanical testing lab:

1. UTM machine
2. Simple bending apparatus
3. Torsion testing machine
4. Charpy's/ Izod testing machine
5. Spring testing machine
6. Brinell/Rockwell hardness testing machine.

Hydraulic lab:

1. Orifice tank
2. Mouthpiece tank
3. Venture meter
4. Orifice meter
5. Bernoulli's apparatus
6. Pipe friction apparatus
7. Centrifugal pump
8. Reciprocating pump
9. Pneumatic circuit kit.



DIRECTORATE OF TECHNICAL EDUCATION
DIPLOMA IN AGRICULTURAL TECHNOLOGY

III YEAR

M SCHEME

IV- SEMESTER

2015-2016(on wards)

COMPUTER AIDED DRAWING PRACTICAL

CURRICULUM DEVELOPMENT CENTRE

M- SCHEME

(Implements from the academic year 2015-2016 onwards)

Course Name : DIPLOMA IN AGRICULTURAL TECHNOLOGY
Course Code : 1222
Subject Code : 32346
Semester : IV
Subject Title : **32346 COMPUTER AIDED DRAWING PRACTICAL**

TEACHING AND SCHEME OF EXAMINATION:

No of weeks per semester: 15 Weeks

Subject	Instruction		Examination			
	Hours	Hours	Marks			Duration
	/week	/Semester	Internal Assessment	Board Examination	Total	
Computer aided Machine Drawing Practical	4 Hrs	60 Hrs	25	75	100	

RATIONALE:

The contemporary progressing world is fast with the latest production systems. The advanced manufacturing of products is developed instantly using CAD Software. Even a small scale industry is now using a CAD software as it has become the heart of the Design department. So CAD has now become inevitable in industries.

Accuracy and Precision are the two important things that decide the quality of a product to survive its competitors in the market. Using CAD software design, the uniform accuracy, multiples of copies and storing in a small space for long time are assured.

The CAD software considerably improves the creativity and flexibility of a designer. The syllabus here enables a candidate to draw an industrial drawing within the optimum reach of a diploma cadre.

OBJECTIVES:

- Appreciate the need of sectional view and types of sections. Draw sectional views using different types of sections.
- Explain the use of threaded fasteners and the types of threads. Compare hole basis system with shaft basis system.
- Select different types of fits and tolerance for various types of mating parts. Practice on CAD commands in making 2D Drawings.
- Draw assembled drawings of different types of joints and couplings using CAD. Draw assembled drawings of various types of machine elements using CAD.

32346 COMPUTER AIDED MACHINE DRAWING PRACTICAL

DETAILED SYLLABUS

Contents: Theory

Unit	Name of the Topic	Hours
I	INTRODUCTION TO CAD SOFTWARE Introduction – History of CAD – Applications – Advantages over manual drafting– Hardware requirements – Software requirements – Windows desktop – CAD screen interface – menus – Tool bars – How to start CAD – How to execute command – types of co-ordinate systems – Absolute – Relative – Polar.	2Hrs
II	DRAWING AIDS AND EDITING COMMANDS Creating objects (2D) – Using draw commands – Line, Arc, Circle, Ellipse, Donut, Polygon, Point, Pline, Sketch, Trace – Creating 2D Solid. Creating text – Dtext, Mtext, Text styles – Mline, spline – Drawing with precision – Osnap options – drafting settings –limits – Units – drawing aids – Fill, Snap, Grid, Ortho lines – Function keys - Editing and modify commands – Object selection methods – Erasing object – Oops - Cancelling and undoing a command – Copy – Move – Array – Offset – Scale – Rotate – Mirror – Break – Trim – Extend – Explode. Divide – Measure – stretch – Lengthen – Changing properties – Color – line types –LT scale – Matching properties – Editing with grips – Pedit – Ddedit – Mledit.	5Hrs
III	BASIC DIMENSIONING, HATCHING, BLOCKS AND VIEWS Basic dimensioning – Editing dimensions – Dimension styles – Dimension system variables. Machine drawing with CAD. Creation of blocks – W block – inserting a block – Block attributes – Hatching –Pattern types – Boundary hatch – working with layers - Controlling the drawing display – Blipmode – View group commands – Zoom, redraw, regen, regen auto, pan, viewres – Real time zoom. Inquiry groups – calculating area – Distance – Time – Status of drawing.	5Hrs
IV	ISOMETRIC DRAWING, PRINTING AND PLOTTING Isometric drawing – Isometric projection – drawing isocircles – Dimensioning isometric objects. File commands – File Import and export – plotting drawing – external references – 3D fundamentals – 2D to 3D Conversion. 3D Drawing: 3D Primitives-Extrude – Revolve-Slice-Section, Surface, 3D Mesh- 3D - Surface-3D Operation-Solid Editing.	4Hrs

V	<p>CAD DRAWING PRACTICE Detailed drawings of following machine parts are given to students to assemble and draw the sectional or plain elevations / plans / and side views with dimensioning and bill of materials using CAD Software.</p>	44
----------	---	-----------

EXERCISES:		
	<p>ASSEMBLY DRAWING:</p> <ol style="list-style-type: none"> 1. Sleeve & Cotter joint 2. Spigot & Cotter joint 3. Gib and Cotter 4. Knuckle joint 5. Stuffing Box 6. Foot step bearing 7. Universal Coupling 8. Bushed Bearing 9. Plummer Block 10. Flanged coupling 	<p>3D Drawing Introduction – simple drawings.</p>

Reference Books:

- 1) Inside AutoCAD - D. Raker and H. Rice - BPB Publications, NewDelhi
- 2) Engineering Drawing and Graphics + AutoCAD – K.Venugopal, - New Age International Publications
- 3) CAD/CAM/CIM - P. Radhakrishnan, S. Subramaniyan and V.Raju - New Age International Publications.
- 4) AutoCAD 2002 with Applications - Sham Tickoo - Tata Mcgraw Hill.
- 5) Computer Graphics, Prentice – Donald Hearn, M. Pauline Baker - Hall of India Pvt. Limited, NewDelhi.

LIST OF EQUIPMENT

1. Personal computer (With latest processor to suit Auto CAD) – 30 No's
2. MS Windows OS – 30 No's
3. AutoCAD software (release 2000 or above) – 30 Users

BOARD EXAMINATIONS			
PART-A	I TO IV UNITS	1 x 10	10 MARKS
PART – B	V UNIT		
	Assembled views		30 marks
	Side view		10 marks
	Bill of materials		5 marks
	Isometric/3D		15 marks
	Viva		5 marks
	Total		75 marks

Note to examiner:

Part A:

Answer any 10 questions out of 15 questions.

Fifteen questions should cover the complete syllabus (UNIT I to IV)

Part B:

Answer should be evaluated from the print out for the Part-B questions.

Examiner should set the question paper to cover the complete syllabus of Unit-V

Examiner has to ask the student to answer any one question from the lot of 10 drawings.

Examiner has to set the no. of questions minimum 10 even one batch of students contains less than 10.

3D Drawing creations the examiner should set the question paper to cover the complete syllabus of Unit-V. 3D Drawings for Part-B 2nd question.



DIRECTORATE OF TECHNICAL EDUCATION

DIPLOMA IN AGRICULTURAL TECHNOLOGY

III YEAR

M SCHEME

IV SEMESTER

2015-2016 (on wards)

ELECTRICAL DRIVES AND CONTROL PRACTICAL

CURRICULUM DEVELOPMENT CENTRE

M-SCHEME

(Implements from the Academic year 2015-2016 onwards)

Course Name : DIPLOMA IN AGRICULTURAL TECHNOLOGY
Course Code : 1222
Subject Code : 32047
Semester : IV
Subject Title : ELECTRICAL DRIVES AND CONTROL PRACTICAL

TEACHING AND SCHEME OF EXAMINATIONS:

No. of Weeks per Semester: 15 Weeks

Subject	Instructions		Examination			Duration
	Hours/ Week	Hours/ Semester	Marks			
Electrical Drives and Control Practical	4	60	Internal Assessment	Board Examination	Total	3 Hrs
			25	75	100	

OBJECTIVES:

- Identify starters for different motors.
- Study and prepare earthing
- Test the characteristics of DC and AC machines.
- Identify and select controlling elements.
- Explore the performance of ELCB, MCB.
- Design regulated power supplies.
- Identify display devices - LED, 7 segment LED, LCD.
- Identify the drive circuit for special motors.
- Test the speed control circuit of the special motors

LIST OF EXPERIMENTS:

Part A:

1. Verification of Ohm's Law
2. Testing of DC starters – 3 point and 4 point starter
3. Load test on DC shunt motor
4. Testing of AC starters- DOL , star - Delta starter
5. Load test on single phase induction motor
6. Load test on three phase squirrel cage motor
7. Testing of relays, contactors, push buttons and limit switch
8. Connection and Testing of MCB, ELCB

Part B

9. Construction and testing of Half wave and Full wave rectifier.
10. Construction and testing of IC voltage regulator using IC 7805.
11. Verification of truth tables for logic gates.
12. Verification of universal gates.
13. Identification and testing of display devices- LED, 7 segment LED, Laser diode.
14. Testing of Stepper motor drive.
15. Testing of Servo motor drive.

BOARD EXAMINATION

Note: All the exercises are to be completed. One exercise from Part A and another one from Part B should be given for the Examination.

Part A:		35
	Circuit diagram	05
	Connections & Readings	15
	Calculations & Graph	15
Part B:		35
	Circuit diagram	05
	Connections & Readings	15
	Execution	15
	Viva Voce	5
	Total	75

LIST OF EQUIPMENTS

Electrical Lab

1. DC ammeter 0-5A	-	1no
2. DC ammeter 0-25A	-	1no
3. DC voltmeter 0-30V	-	1no
4. DC voltmeter 0-300V	-	1no
5. Rheostat 10.8 ,8.5A	-	1no
6. AC ammeter 0-5A	-	1no
7. AC ammeter 0-10A	-	2nos.
8. AC voltmeter 0-50V	-	3nos
9. AC wattmeter 5A-10A (0-750W,0-600V)	-	3nos
10. Loading rheostat 5A,230V	-	1no
11. Tachometer 0-1000rpm (Analog type)	-	1no
12. Variac 20A,250V (Auto transformer)	-	2nos
13. 3 point starter 20A,220V	-	1no
14. DOL starter 16A,415V	-	1no

15. Star /Delta starter 20a,600V	-	1no
16. Over load relay 1 to 2.5A	-	1no
17. Air break contactors 20A,220V	-	4nos
18. Push button 2A ,220V	-	2nos
19. Limit switch 20A,220V	-	1no
20. MCB 20A single pole	-	1no
21. MCB 20A double pole	-	1no
22. ELCB 2pole 20A,100mA	-	1no
23. ELCB 4POLE 20A,100mA	-	1no

Electronics Lab

1. Transformer 230 / 9-0-9V, 1A	-	4 nos.
2. Resistor 1 K Ω / ½ W	-	3 nos.
3. Capacitor 1000 μ F/25V	-	4 nos.
4. IC 7805	-	1 no.
5. Logic Gates IC		
7400, 7408, 7432, 7404, 7402, 7486-		1 each
6. Stepper Motor Drive kit	-	1no.
7. Servo Motor Drive Kit	-	1no
8. Digital Multimeter	-	1no.
9. LED, 7Segment LED, Laser Diode -		1 each

V SEMESTER



DIRECTORATE OF TECHNICAL EDUCATION

DIPLOMA IN AGRICULTURAL TECHNOLOGY

III YEAR

M SCHEME

V- SEMESTER

2015-2016 (on wards)

TRACTOR AND ITS POWER UNITS

CURRICULUM DEVELOPMENT CENTRE

M – SCHEME

(Implements from the academic year 2015-2016 onwards)

Course Name : DIPLOMA IN AGRICULTURAL TECHNOLOGY
Course Code : 1222
Subject Code : 32351
Semester : V
Subject Title : **TRACTOR AND ITS POWER UNITS**

TEACHING AND SCHEME OF EXAMINATION:

No of weeks per semester: 15 Weeks

Subject	Instruction		Examination			Duration
	Hours /week	Hours /Semester	Marks			
			Internal Assessment	Board Examination	Total	
Tractor And Its Power Units	6 Hrs	90 Hrs	25	75	100	3 Hrs

Topics and Allocation of Hours:

Unit No	Topic	Time (Hrs)
I	IC Engines	17
II	Fuel – Air Intake System	17
III	Other System Of An Engine	17
IV	Power Transmission System	16
V	Braking And Hydraulic System	16
	Test & revision	7
	Total	90

RATIONALE:

To effectively manage and produce from Agriculture one needs Power. Today, the agricultural sector faces severe labour shortages. To overcome these problems the use of mechanical power is essential. One who studies agricultural engineering must know the intricacies of mechanical power source namely Tractor.

OBJECTIVES:

- To study and understand various components of a tractor
- To know about diesel engine and power transmission system.
- To study fuel-air intake system
- To study the cooling system of IC engine.
- To study Lubrication system
- To study Braking and Hydraulic System.

V SEMESTER AGRICULTURAL TECHNOLOGY

32351 TRACTOR AND ITS POWER UNITS

DETAILED SYLLABUS

Unit	Name of topic	Hours
I	<p>IC ENGINE</p> <p>1.1 INTERNAL COMBUSTION ENGINE: Engine – introduction – classification of engine- Principle of Operation of IC engine – petrol engine and diesel engine – Gas Laws (Charles, Boyles law) –diesel cycle – valve timing diagram of diesel engine – Comparison of CI and SI engines.</p> <p>Basic terminologies of engine: Bore and Stroke – Piston Displacement (Swept volume) – Compression ration – Horsepower – IHP- BHP – Mean Effective Pressure – Volumetric efficiency- Simple problems. Cylinder arrangements- Valve arrangements- Firing order- Firing Interval- valve timing diagram of a diesel engine.</p> <p>1.2 Engine Components: Constructional Details of Engine, Cylinder, Cylinder head, gasket, cylinder liners, Piston-function of Piston , Piston rings, piston pins, combustion chambers, crank case, oil sump, connecting rod, crank Shaft, cam shaft, timing gear, Fly wheel, Engine bearing – Valve and Valve mechanisms – flywheel.</p>	17
II	<p>FUEL – AIR INTAKE SYSTEM</p> <p>2.1 FUEL SYSTEM : Diesel engine fuel – requirement – properties – cetane number– diesel knock. Requirement of fuel injection system-Methods of fuel injection – direct injection – diesel engine fuel system layout – components of fuel system – fuel tank – fuel filter (paper element) – A.C. Mechanic feed pump. Fuel injection Pump (general type) - fuel injectors (atomizer) – types of nozzles – bleeding of injection system. Governing System – purpose – pneumatic governor.</p> <p>2.2 AIR INTAKE AND EXHAUST SYSTEM: Pre-cleaner – air cleaner – types – wetted type, dry type and oil bath type – intake manifold – super charge-types – turbocharger. Exhaust system – exhaust manifold – exhaust pipe – mufflers – types(briefly)- scavenging- types.</p>	17
III	<p>OTHER SYSTEM OF AN ENGINE</p> <p>3.1 COOLING SYSTEM OF IC ENGINE: Cooling system – need – methods of cooling Air Cooling, Water Cooling, liquid cooling, steam cooling – Components of water Cooling system-servicing of cooling system.</p> <p>3.2 LUBRICATION SYSTEM: Object of lubrication in IC</p>	17

	<p>engines – Function of Engine Oil – Properties of Lubricants – Types of lubricants – Lubricating parts – methods of lubrication – parts of lubricating system – pumps – oil filters – types oil strainer- oil cooler- oil level indicator – pressure gauge(only types) – Crank Case ventilation.</p> <p>3.3 CHARGING SYSTEM: Battery – types – construction of lead – acid battery. Starting motor(simple type) – alternator(general type) – cut out relay – starting and charging circuit – simple wiring diagram.</p>	
IV	<p>POWER TRANSMISSION SYSTEM:</p> <p>4.1 CLUTCH: Function – principles of Operation – Types of Clutches – Working of single Plate Clutch – Multi-plate clutch – clutch adjustment.</p> <p>4.2 GEAR BOX: Gear box function – Types of gear box – sliding mesh – constant mesh – synchromesh gear box.</p> <p>4.3 DIFFERENTIAL – function – construction and working – differential lock - back lash adjustment – final drive. Rear axle-types (briefly).</p> <p>4.4 STEERING SYSTEM: Requirement – function – steering geometries – steering gear box – cam and roller type, rack and pinion type, Re-circulating ball type – front axle – live and dead axle. Power steering (briefly)- stub axle-types-front axle assembly.</p>	16
V	<p>BRAKING AND HYDRAULIC SYSTEM</p> <p>5.1 Brakes: Classification of brakes – functions – mechanical brake – disc brake- Hydraulic brakes – master cylinder and wheel cylinder – bleeding of hydraulic brake system-brake adjustments.</p> <p>5.2 Tyres and Tubes: Tyres- types - Construction of Pneumatic tyre – tyre properties- size and Ply rating – Tubes.</p> <p>5.3 Hydraulic System: Principles of hydraulics – working of hydraulic system – implement control – position control – draft control – mixed position and draft control</p>	16

Text books: 1) Farm Tractors maintenance and repair by S.C. Jain and C.R. Rai.
2) Automobile Engineering by R.B. Gupta
3) Automobile Engineering by Dr. Kripal Singh
4) Automobile Engineering by K.K. Jain and R.B. Asthana.



DIRECTORATE OF TECHNICAL EDUCATION
DIPLOMA IN AGRICULTURAL TECHNOLOGY

III YEAR

M SCHEME

V SEMESTER

2015-2016(on wards)

FARM MACHINERY

CURRICULUM DEVELOPMENT CENTRE

M- SCHEME

(Implements from the academic year 2015-2016 onwards)

Course Name : DIPLOMA IN AGRICULTURAL TECHNOLOGY
Course Code : 1222
Subject Code : 32352
Semester : V
Subject Title : **FARM MACHINERY**

TEACHING AND SCHEME OF EXAMINATION:

No of weeks per semester: 15 Weeks

Subject	Instruction		Examination			Duration
	Hours /week	Hours /Semesters	Marks			
			Internal Assessment	Board Examination	Total	
Farm Machinery	6 Hrs	90 Hrs	25	75	100	3 Hrs

Topics and Allocation of Hours:

Unit No	Topic	Time (Hrs)
I	PRIMARY TILLAGE IMPLEMENTS	17
II	SECONDARY TILLAGE IMPLEMENTS	17
III	SOWING AND PLANTING MACHINES	17
IV	PLANT PROTECTION EQUIPMENTS	15
V	HARVESTING AND THRESHING MACHINES	17
	Test & revision	7
	Total	90

RATIONALE :

Agricultural engineering is the study of applications of various branches of engineering in the field of agriculture with the aim of production maximization. Farm Machinery is one of the core subjects in the field of Agricultural engineering. Today, the field of agriculture is not liked by almost all laborers. Since agricultural activities are cumbersome and tiresome. To feed all the population in the universe we must carry on agriculture.

To do so we must mechanize agricultural activities like Ploughing, harvesting, threshing, plant protection etc,. There are a number of hindrance or constraints in mechanization like small land holding, cost of the equipment, lack of education etc,. To offset these problems one must study the various implements and equipments available and their operations must be thoroughly known. Since diploma level students are placed in maintenance, repair and service activities much importance is given to these areas of implements and equipments in this subject Farm Machinery.

OBJECTIVES :

- To study the constructional features of mould board plough, disc plough, subsoilers, operation, care and maintenance.
- To study on rotary tiller, components, power transmission and maintenance.
- Secondary tillage implements, different types of harrows and their operating procedures.
- Constructional features of seed drills-seed metering mechanisms.
- Calibration of seed drill.
- Study on constructional features of planters.
- Various types of sprayers-components.
- Different types of dusters-components.
- Harvesting machines-reapers-components.
- Threshing machines-different types-operations-care and maintenance.

**32352 FARM MACHINERY
DETAILED SYLLABUS**

Contents : Theory

Unit	Name of the topic	Hours
I	<p>Primary Tillage Implements Tillage – objectives of tillage – classification and type of tillage – primary tillage & secondary tillage – types of plough – Indigenous plough – parts – mould board – plough Accessories – Adjustments of mould board plough – disc plough – advantages and disadvantages – types of disc plough – disc angle – Tilt angle – Scraper – concavity. Adjustments and Repairs of plough – other plough – chisel plough – Subsoiler – Rotary plough – Rotavator – Terms related to field performance of machines (definition only)</p>	17Hrs
II	<p>Secondary Tillage Implements: Definition – Objectives – Harrow – Types – Disc Harrow – Classification – Constructional features – Operational techniques – Implement adjustment – operating procedure – Maintenance – Trouble shooting – Possible causes and possible remedies. Spike tooth harrow – Spring type harrows, Blade Harrows – power Harrow – Roller Harrow – Cultivators.</p>	17Hrs
III	<p>Sowing and Planting Machines: Seed drill – Types of seed drill – Constructional features – Seed metering mechanism – Fluted Roller – Internal double run – Orifice type - cup type – fertilizer metering mechanism – Seed/ Fertilizer dropping unit – Furrow opener – calibration of seed drill – - operation procedure – care and maintenance- precautions. Planters- method of planting-types of planters- constructional features-field operation and adjustment–special crop planters- potato planter- manual Rice Transplanter (only).</p>	17Hrs
IV	<p>Plant Protection Equipments Introduction – Physical classification of pesticides – classification of Sprayer – Types and sizes of sprayers – Stirrup pump sprayers - Bucket – Hand compression Sprayer – Foot Sprayer – Rocking Sprayers – Knapsack sprayers - Spraying volume – High volume, Low volume, ULV – Duster, Manually operated, plunger duster, Hand rotary duster, bellow duster, Power operated duster- Spinning disc applicator, thermal foggers – safety precautions – Troubles occurring in various plant protection equipments – selection of plant protection equipment.</p>	15Hrs
V	<p>Harvesting and Threshing Machines</p>	

Thresher – Introduction – Working principle – Constructional features – Different types of feeding system – Types of power threshers – Drummy type – Hammer mill type - syndicator type - spike tooth type – wire loop type – Rasp bar type – Axial flow type – Multi-crop thresher. Installation – Adjustments in a thresher – Safety precautions Maintenance – Trouble shooting. Combine harvester – Self propelled tractor operated – functions of combined harvester – Construction features - cutter bar, Threshing unit – combine operation – combine performance – Maintenance.
--

Text book:

- 1) Farm Machinery – An approach Authors: S.C. Jain & Grace Philip.
Publisher: Standard Publishers, Distributors, 1705, Nai Sarak, P.B.NO.1066, ND.

Reference Books:

- 1) Principles of Agricultural Engineering, Vol. I, A.M. Michael & T.P. Ojh
- 2) Elements of Agriculture Engineering Dr. Jagdishwar Sahai, Agro Book Agency, New Chitragupta Nagar, Patna – 20.
- 3) Principles of farm machinery, R.A. Kepner, Roy Bainer, E.L. Berger.



DIRECTORATE OF TECHNICAL EDUCATION

DIPLOMA IN AGRICULTURAL TECHNOLOGY

III YEAR

M SCHEME

V SEMESTER

2015-2016 (on wards)

POST HARVEST TECHNOLOGY

CURRICULUM DEVELOPMENT CENTRE

M – SCHEME

(Implements from the academic year 2015-2016 onwards)

Course Name : DIPLOMA IN AGRICULTURAL TECHNOLOGY
Course Code : 1222
Subject Code : 32371
Semester : V
Subject Title : **POST HARVEST TECHNOLOGY**

TEACHING AND SCHEME OF EXAMINATION:

No of weeks per semester: 15 Weeks

Subject	Instruction		Examination			Duration
	Hours /week	Hours /Semesters	Marks			
Post Harvest Technology	5 Hrs	75 Hrs	Internal Assessment	Board Examination	Total	3 Hrs
			25	75	100	

Topics and Allocation of Hours:

Unit No	Topic	Time (Hrs)
I	PROPERTIES OF GRAINS	14
II	DRYING	14
III	PARBOILING	14
IV	MILLING	13
V	PROCESSING OF OIL SEED AND RICE BRAN	13
	Test & revision	7
	Total	75

RATIONALE:

Post harvest Technology is one of the core subject in Agricultural engineering study. There is a common feeling among farmers that their produce is not giving enough or good return to them. More over the post harvest losses are much higher. This leads to food shortages to the people. To adders all these issues Postharvest technology is studied.

Various techniques like value addition to the agricultural produce, drying and its importance, parboiling, milling, oil extraction are some of the ways by which the farmer can get more remunerative price to his produce.

OBJECTIVES:

- To understand the structure, physical and chemical properties of the various food grains. Understanding of this properties helps in design of processing machines and equipments
- To understand mechanism of drying and importance of drying
- To know the working of various dryers
- To understand the mechanism and importance of parboiling.
- To study the various parboiling techniques.
- To know the mechanism of milling and various milling machineries.
- To understand rice milling and modern rice milling concept.
- To know the extraction and refining of vegetable oils.
- To know the rice bran processing techniques.

32371 POST HARVEST TECHNOLOGY

DETAILED SYLLABUS

Contents : Theory

Unit	Name of the topic	Hours
I	PROPERTIES OF GRAINS: Structure of a grain – chemical composition – effect of temperature on quality of grain. Physical Properties – thermal properties – mechanical properties. Humidity – percentage humidity – relative humidity – humid heat enthalpy – humid volume – saturated volume – dew point. Moisture Content – dry basis, wet basis – relation between them – simple problems – moisture measurements – different methods. Concept of equilibrium moisture content – determination EMC- Henderson's equation – simple problems.	14 Hrs
II	DRYING: Thin Layer drying and deep bed drying – principles – constant rate of drying – falling rate of drying – need for drying – Newton's Equation for drying (MR). Factors affecting drying – different grain drying methods – conduction, convection and radiation – natural air drying, supplemental heat drying, heated air drying – other types of drying. Dryers – basics classification – unheated air dryers – heated air dryers – flat bed dryers – columnar dryers – re-circulatory batch dryer continuous flow columnar dryer – L.S.U. dryer – baffle type dryer – rotary dryer – advantages and disadvantages of dryers.	14 Hrs
III	PARBOILING Parboiling definition – principles of parboiling – Advantages and Disadvantages of parboiling – soaking – steaming – drying – methods of parboiling – Traditional methods of parboiling – CFTRI methods – Kissan Continuous process – pressure parboiling – RPEC method – sodium chromate method – drying of parboiled paddy – Sun drying – mechanical drying.	14 Hrs

IV	<p>MILLING</p> <p>Definition – various milling processes – cleaning, grading and sorting – different types of separators – properties influencing separation. Husking/hulling of grains – method of husking.</p> <p>Grinding – Factors affecting grinding – grinding of grain in roller mills – grinding grain in hammer mill.</p> <p>Rice milling – Engelburg huller – advantages and disadvantages – Sheller – rubber roll sheller – advantages and disadvantages – polishing – vertical polisher- horizontal polisher.</p>	13 Hrs
V	<p>PROCESSING OF OIL SEED AND RICE BRAN</p> <p>Introduction – constituent of oils - classification of oils – their uses – extraction of oil from oil seeds – Extraction and refining of cotton seed oil – Extraction of soyabean oil – extraction of sunflower oil – extraction of palm oil – extraction of coconut oil – traditional method and mechanical extraction.</p> <p>Rice bran oil – composition of rice bran oil – problem faced in processing of rice bran oil – factors affecting storage of rice bran oil – extraction of the bran oil – solvent extraction and Batch extraction method – refining of crude rice bran oil – uses of bran oil and various constituents.</p>	13 Hrs

REFERENCE BOOKS:

1. Principal of Agricultural Engineering Vol. 1 A.M. Micheal & T.P. Ojha – Jain brothers, New Delhi.
2. Post Harvest Technology of cereals, pluses and oil seeds by A. Chakraverty, Oxford & IBH Publishing, New Delhi.
3. Rice Post Harvest Technology by E.V. Araullo, D.B. de Padua & Michael Grahon, Oxford & IBH Publishing, New Delhi.
4. Agricultural Engineering (through worked Example) by Radheh Lal, et al Sanjay Prakasam Publishers, katra, Allahabad – 211 002.
5. Rice Process Technology By S. Bandyapadhyar & Roy Oxford & I.B.H. Publication



DIRECTORATE OF TECHNICAL EDUCATION

DIPLOMA IN AGRICULTURAL TECHNOLOGY

III YEAR

M SCHEME

V SEMESTER

2015-2016 (on wards)

FOOD PROCESS ENGINEERING

CURRICULUM DEVELOPMENT CENTRE

M – SCHEME

(Implements from the academic year 2015-2016 onwards)

Course Name : DIPLOMA IN AGRICULTURAL TECHNOLOGY
Course Code : 1222
Subject Code : 32372
Semester : V
Subject Title : **FOOD PROCESS ENGINEERING**

TEACHING AND SCHEME OF EXAMINATION:

No of weeks per semester: 15 Weeks

Subject	Instruction		Examination			Duration
	Hours /week	Hours /Semesters	Marks			
			Internal Assessment	Board Examination	Total	
Food Process Engineering	5 Hrs	75 Hrs	25	75	100	3 Hrs

Topics and Allocation of Hours:

Unit No	Topic	Hours
I	UNIT OPERATION IN FOOD PROCESSING	14
II	POULTRY, FISH PROCESSING & FOOD STANDARDS	14
III	MILK PROCESSING	14
IV	PROCESSING OF VEGETABLES AND FRUITS	14
V	BEVERAGES	12
	REVISION & TEST	5
	Total	75

RATIONALE:

The very need of the hour today in Agricultural Engineering and Technology is food processing. Only well processed items are edible and eligible not only for current use but also for storage for future requirements. So it is very essential for the students of this discipline to know about the technology of food processing. The technology not only provides defect free high quality and nutritious food items, but also enables storing of items for long time without any degradation in quality and nutritive values.

As Poultry, Fish, Vegetables, Fruits, Milk and Beverages are the main foods of one above items to the humankind, it is essential to impart the knowledge of processing of students of Agricultural Engineering.

The knowledge of the processing methods can meet the demand of the items during some serious situation like off seasons, natural calamity periods and the like. It also can help the students to become entrepreneur in this field. The knowledge is essential to avoid appreciable wastage and spoilage of valuable food items and get notable foreign exchange by exporting.

OBJECTIVES:

- To understand the various unit operations involved in food processing industry.
- To know the various food processing Techniques.
- To know the poultry processing, composition and its nutritive values.
- To know about the fish composition, nutritive value, preservation and storage.
- To know about the food additives.
- To know the various standards in food processing industry.
- To understand milk food processing and various types of Milk.
- To know about the processing of vegetables, its nutritive values and post harvest practices.
- To know about the preparation of Fruit Juice, Jelly and Jam.
- To know the processing of coffee and tea.

**32372 FOOD PROCESS ENGINEERING
DETAILED SYLLABUS**

Contents : Theory

Unit	Name of the Topic	Hours
I	<p>UNIT OPERATION IN FOOD PROCESSING</p> <p>Food Processing – Introduction – Types of Foods – Refining and Milling – Canning – Concentration – Freezing – Drying – Pasteurization and Sterilization – Fermentation – Irradiation – Packing (Brief introduction only).</p> <p>Food Preservation – Principles and methods – Importance of Food Preservation - Food Adulteration – Common adulterants and simple detection Techniques – Food Storages – (Cold Storage).</p>	14
II	<p>POULTRY, FISH PROCESSING & FOOD STANDARDS</p> <p>Poultry – Classification – processing – composition and nutritive value – slaughter and bleeding – scalding – defeathering – canning – dehydration – Chilling – freezing.</p> <p>Fish – classification – composition and nutritive value – selection – spoilage – factors – preservation and storage – cold storage – canning – chilling – freezing – curing – pickling or smoking – salting and drying.</p> <p>Food Additives – Definition – Need of Additives in Food processing Industry – Broad classes of International Food Additives (Names and their brief description only).</p> <p>Food standards – Health ministry standards – Agmark – BIS standards – Consumer protection Act (Brief introduction only). Food labeling – FPO Labeling – ISI mark (Brief introduction only).</p>	14
III	<p>MILK PROCESSING</p> <p>Procurement of Milk – Pricing of Milk – Chilling plant – Transportation – receiving Milk at Dairy plant – Quality evaluation – Organoleptic tests – sampling – laboratory tests for Milk – Detection of Adulterants – Bacteriological quality Tests. Processing of Milk – Methods of Pasteurization – HTST, Batch/Holding type and in bottle pasteurization – Sterilization in bottle and UHT methods – Bottling – Packaging caps and capping – storage and distribution, Marketing – Defects in Milk.</p> <p>Special Milks – standardized Milk, Toned Milk, Double Toned Milk, Homogenized milk, filled milk, condensed milk, Flavoured milk (Definition only).</p>	14

IV	<p>PROCESSING OF VEGETABLES AND FRUITS</p> <p>Vegetables – Definition – classification – composition and nutritive values – selection – storage – post harvest practices – washing – skin removal – cutting and trimming – branching – canning – ascorbic acid dip – sulphur dioxide dip – sugar syrup – vacuum treatment – fruits – classification – composition and nutritive value – ripening- induced ripening of fruits – storage.</p> <p>Fruits for juice production – selection and preparation – juice preparation – jelly preparation – jam preparation.</p>	14
V	<p>BEVERAGES</p> <p>Definition – classification – ingredients – coffee processing – roasting – grinding – blending – brewing – decaffeinated coffee – instant coffee – extraction – dehydration – aromatization – methods of coffee making.</p> <p>Tea – leaf processing – black tea – green and oolong tea – instant tea – preparation of tea.</p>	12

Reference Books:

1. Food science (Fifth edition) Norman N. POTTER, Joseph H. Hotchkiss
CBS Publishers & Distributors Pvt. Ltd. Chennai – 20, West park road,
Shenoy Nagar.
2. Food Science (Fourth Edition) B. Srilakshmi. New Age International (P) Ltd.
4835/24, Ansari road, Daryaganj. New Delhi 110002.
3. Chemical Process Industries. (Fifth edition) 1984. George T. Austin.
McGraw Hill book company. NewYork.



DIRECTORATE OF TECHNICAL EDUCATION

DIPLOMA IN AGRICULTURAL TECHNOLOGY

III YEAR

M SCHEME

V SEMESTER

2015-2016 (on wards)

**RENEWABLE ENERGY SOURCES AND ENERGY
CONSERVATION**

CURRICULUM DEVELOPMENT CENTRE

M-SCHEME

(Implements from the Academic year 2015-2016 onwards)

Course Name : DIPLOMA IN AGRICULTURAL TECHNOLOGY
Course Code : 1222
Subject Code : 32073
Semester : V
Subject Title : RENEWABLE ENERGY SOURCES AND ENERGY CONSERVATION

TEACHING AND SCHEME OF EXAMINATIONS:

No. of Weeks per Semester: 15 Weeks

Subject	Instructions		Examination			Duration
	Hours/ Week	Hours/ Semester	Marks			
Renewable Energy Sources and Energy Conservation	5	75	Internal Assessment	Board Examination	Total	3 Hrs
			25	75	100	

Topics and Allocation of Hours:

Unit	Topics	Hours
I	FUNDAMENTALS OF ENERGY, WIND ENERGY	14
II	SOLAR ENERGY, APPLICATION, STORAGE	14
III	SOLAR PHOTOVOLTAIC SYSTEM AND DESIGN, OCEAN, TIDAL, WAVE ENERGY	14
IV	BIO-ENERGY	13
V	ENERGY CONSERVATION TECHNIQUES AND ENERGY AUDIT	13
	REVISION AND TEST	7
	TOTAL	75

RATIONALE:

Electrical Energy requirement is the major crisis and hence any saving in Electrical energy is equivalent to production of Electrical Energy. Saving can be achieved by the utilization of Renewable Energy Sources.

OBJECTIVES:

- Study about the fundamentals of Energy.
- Study of construction and principle of Wind energy, Solar energy, Tidal energy and Bio energy.
- Understand the PV design and its components.
- Understand the energy management and auditing techniques.
- Study the energy conservation process.

**RENEWABLE ENERGY SOURCES AND ENERGY CONSERVATION
DETAILED SYLLABUS**

Contents: Theory

Unit	Name of the Topic	Hours
I	FUNDAMENTALS OF ENERGY Introduction to Energy-Energy consumption and standard of living-classification of energy resources-consumption trend of primary energy resources-importance of renewable energy sources- energy for sustainable development. WIND ENERGY Introduction-Basic principles of wind energy conversion: Nature of the wind, power in the wind, forces on the blades and wind energy conversion-wind data and energy estimation-site selection-classification of wind energy conversion systems- components of conversion systems-Advantages and Disadvantages-Types of wind machines-Horizontal axis machine-Vertical axis machine-Generating system-Energy Storage–Application of wind energy-Safety and environmental aspects.	14

II SOLAR ENERGY

14

Introduction – Solar radiation at the earth's surface-Solar Radiation measurements-Estimation of average solar Radiation.

Solar energy collectors- Classifications-Flat plate collectors - Concentrating collectors-performance parameter-tracking system-compound parabolic concentrator-parabolic trough concentrators-concentrator with point focus-heliostats-comparisons of various collectors-efficiency of collector-selection of collector for various applications.

Solar Thermal Application: Solar water heaters-Solar industrial heating system – Solar Refrigeration and Air-Conditioning Systems-Solar cookers-Solar furnaces-Solar greenhouse-Solar Distillation-Solar pond Electric power plant-Distributed Collector- Solar thermal Electric power plant.

Solar thermal energy storage: sensible storage-latent heat storage-thermo chemical storage.

III Solar photovoltaic System and Design:

14

Solar photovoltaic a brief history of PV,PV in silicon: basic principle, crystalline PV; reducing cost and raising efficiency, thin film PV, other innovative technologies, electrical characteristics of silicon PV cells and modules, grid connected PV system, cost of energy from PV ,Environmental impact and safety.

System design of solar photovoltaic system: Load analysis-solar array Design-Battery Design-Simple formulas. System design procedure. Case Studies: Designing solar home lighting system - Designing stand alone solar PV Power plant - Designing solar PV water pumping system - Only arriving load capacity - solar array sizing - Battery sizing - Inverter capacity and mountings.

Ocean energy, Tidal & Wave energy

Ocean energy resources – principle's of ocean thermal energy conversion (OTEC) – Methods of Ocean thermal electric power generation – Energy utilisation – basic principle of tidal power – components and operations of tidal power plant – Energy and Power forms of waves – Wave energy conversion devices.

IV BIO – ENERGY

13

Introduction – photo synthesis – usable forms of bio mass, their composition and fuel properties-Biomass resources – Biomass conversion technologies – Urban waste to energy conversion – Biomass gasification – biomass liquification – biomass to ethanol production – Biogas production from waste Biomass – types of bio gas plants - applications – Bio diesel production – Biomass energy programme in India.

V Energy Management and Audit, Conservation: Definition, Energy **13**

audit - need, Types of energy audit, Energy management (audit) approach-understanding energy costs, Bench marking, Energy performance, Matching energy use to requirement, Maximizing system efficiencies, Optimizing the input energy requirements, Fuel and energy substitution, Energy audit instruments

Energy Conservation Techniques- Need and importance of energy conservation -Principles of energy conservation- Methods of energy conservation-Cogeneration and its application-Combined cycle system-Concept of energy management-Study of different energy management techniques like-Analysis of input-Reuse and recycling of waste.

Economic approach of Energy Conservation-Costing of utilities like steam, compressed air, electricity and water-Ways of improving boiler efficiency-Thermal insulation, Critical thickness of insulation-Waste heat recovery systems, their applications, criteria for installing unit-An introductory approach of energy conservation in compressed air, refrigeration, air conditioning, pumps and fans.

Text Books:

- 1) Non Conventional Energy Sources - G.D. Rai – Khanna Publishers, New Delhi,1999.
- 2) Non Conventional Energy Sources and Utilisation - R.K. Rajput - S.Chand & Company Ltd., 2012.
- 3) Renewable Energy Sources - Twidell, J.W. and Weir, A. - EFN Spon Ltd., 1986.

- 4) Non-Conventional Energy Resources - B.H.Khan - Tata Mc Graw Hill, 2nd Edn, 2009.
- 5) Industrial energy conservation- D. A. Ray- Pergaman Press
- 6) Energy resource management- Kirpal Singh Jogi- Sarup and sons



DIRECTORATE OF TECHNICAL EDUCATION

DIPLOMA IN AGRICULTURAL TECHNOLOGY

III YEAR

M SCHEME

V SEMESTER

2015-2016 (on wards)

TRACTOR AND ITS POWER UNITS PRACTICAL

CURRICULUM DEVELOPMENT CENTRE

M – SCHEME

(Implements from the academic year 2015-2016 onwards)

Course Name	:	DIPLOMA IN AGRICULTURAL TECHNOLOGY
Course Code	:	1222
Subject Code	:	32354
Semester	:	V
Subject Title	:	TRACTOR AND ITS POWER UNITS PRACTICAL

TEACHING AND SCHEME OF EXAMINATION:

No of weeks per semester: 15 Weeks

Subject	Instruction		Examination			Duration
	Hours /week	Hours /Semesters	Marks			
Tractor and its Power Units Practical	4 Hrs	60 Hrs	Internal Assessment	Board Examination	Total	3 Hrs
			25	75	100	

RATIONALE:

To effectively manage and produce from Agriculture one needs Power. Today, the agricultural sector faces severe labour shortages. To overcome these problems the use of mechanical power is essential. One who studies agricultural engineering must know the intricacies of mechanical power source namely Tractor.

To impart necessary skills in the field of Tractor and its Power units the corresponding practical's is offered along with theory subjects.

GUIDELINES:

All the fifteen experiments must be completed and given for end semester practical examination.

The experiments should be conducted sequentially as per in the list

ALLOCATION OF MARKS

Examination Duration: 3 Hrs	Max Marks
Dismantling and reassembling	40
Sketch and description (study cycles)	15
Components Identification or parts	10
Short note on commercial tractor Workshop	5
Viva Voice	5
Total	75

M – SCHEME

32354 – TRACTOR AND ITS POWER UNITS PRACTICAL

COMPLETE LIST OF EXPERIMENTS IN DETAIL

Cycle I(Engine)

1. Engine dismantling and assembling
2. Overhauling of diesel engine
3. Valve timing of four stroke Diesel engine
4. Venting of fuel system and servicing of fuel system (air lock releasing)
5. Servicing of inlet and exhaust system (Pre cleaner, oil bath air cleaner, silencer cleaning)
6. Servicing of cooling system (Flushing of Radiator)
7. Servicing of Lubricating system

Cycle II (Transmission System)

1. Dismantling and assembling of Clutch system, Adjustment and Identification of Parts in Clutch system in a Tractor
2. Dismantling and reassembling of Gear Box and Identification of parts.
3. Servicing of differential and backlash adjustments, differential lock(Briefly explain)
4. Servicing of braking system and adjustments
5. Bleeding of hydraulic brake system
6. Servicing of steering system
7. Rear wheel space adjustments, measuring of vehicle specifications
8. Workshop visit.

List of equipments required to impart experiment/exercise with number for a batch of 30 students.

1. Diesel engine.
2. Gear box.
3. Differential.
4. Braking system.
5. Steering system.
6. Tractor.
7. Spanner set and other tools.
8. Jack and other special tools.



DIRECTORATE OF TECHNICAL EDUCATION

DIPLOMA IN AGRICULTURAL TECHNOLOGY

III YEAR

M SCHEME

V SEMESTER

2015-2016 (on wards)

PROCESS AUTOMATION PRACTICAL

CURRICULUM DEVELOPMENT CENTRE

M-SCHEME

(Implements from the Academic year 2015-2016 onwards)

Course Name : DIPLOMA IN AGRICULTURAL TECHNOLOGY
Course Code : 1222
Subject Code : 32055
Semester : V
Subject Title : PROCESS AUTOMATION PRACTICAL

TEACHING AND SCHEME OF EXAMINATIONS:

No. of Weeks per Semester: 15 Weeks

Subject	Instructions		Examination			Duration
	Hours/ Week	Hours/ Semester	Marks			
Process Automation Practical	4	60	Internal Assessment	Board Examination	Total	3 Hrs
			25	75	100	

OBJECTIVES:

- Design and operate pneumatic circuits.
- Design and operate fluid power circuits
- Use PLC system and its elements for process control
- Familiarize the working of function blocks in PLC
- Use ON-Delay timer to control a motor
- Use OFF-Delay timer to control a motor
- Use counter function block (Up counter and Down counter)
- Control the automatic operation of pneumatic cylinder using PLC
- Record of work to be prepared.

Exercises

Pneumatics Lab.

1. Direct operation of single and double acting cylinder.
2. Operation of double acting cylinder with quick exhaust valve.
3. Speed control of double acting cylinder using metering-in and metering-out circuits.
4. Automatic operation of double acting cylinder in single cycle - using limit switch.
5. Automatic operation of double acting cylinder in multi cycle - using limit switch.

Hydraulics Lab.

1. Direct operation of double acting cylinder.
2. Direct operation of hydraulic motor.
3. Speed control of double acting cylinder metering-in and metering-out control.

PLC Lab.

1. Direct operation of a motor using latching circuit.
2. Operation of a motor using 'AND' logic control.
3. Operation of a motor using 'OR' control.
4. On-Delay control of a motor and Off –Delay control of a motor.
5. Automatic operation of a Double acting cylinder-single cycle.
6. Automatic operation of a Double acting cylinder-single cycle - forward, time delay, return.
7. Automatic operation of Double acting cylinder-Multi cycle.
8. Sequential operation of double acting cylinder and a motor.

Board of Examination

Note: All the exercises have to be completed. Two exercises will be given for examination by selecting one exercise from Pneumatics Lab. or Hydraulics lab. and one from PLC lab.

All the exercises should be given in the question paper and students are allowed to select by a lot.

Record note book should be submitted during examination.

Allocation of Marks

Part A: Pneumatics/Hydraulics lab by lot	- 35 marks
Part B: One question from PLC lab.	- 35 marks
Viva-voce	- 05 marks
Total	- 75 marks

LIST OF EQUIPMENTS

1. Pneumatic Trainer Kit – 2Nos
(All Cylinders, Control Valves, Limit switches and other accessories)
2. Hydraulics Trainer Kit – 1No.
(All Cylinders, Control Valves, Limit switches and other accessories)
3. Pneumatic Trainer Kit with PLC. – 2 Nos.
(All Cylinders, Control Valves, Limit switches and other accessories)



DIRECTORATE OF TECHNICAL EDUCATION

DIPLOMA IN AGRICULTURAL TECHNOLOGY

III YEAR

M SCHEME

V SEMESTER

2015-2016 (on wards)

**MACHINESHOP- I PRACTICAL
(LATHE & WELDING)**

CURRICULUM DEVELOPMENT CENTRE

M-SCHEME
(Implements from the Academic year 2011-2012 onwards)

Course Name : DIPLOMA IN AGRICULTURAL TECHNOLOGY
Course Code : 1222
Subject Code : 32356
Semester : V
Subject Title : **MACHINESHOP- I PRACTICAL**
(LATHE AND WELDING)

TEACHING AND SCHEME OF EXAMINATIONS:

No. of Weeks Per Semester: 15 Weeks

Subject	Instruction		Examination			Duration
	Hours /week	Hours /Semesters	Marks			
			Internal Assessment	Board Examination	Total	
Machine shop-I (Lathe and Welding)Practical	5 Hrs	75 Hrs	25	75	100	3 Hrs

RATIONALE:

It is very much important to impart basic welding skills to the Diploma Engineer as it is one of the most important manufacturing and salvaging technique.

They should be given training to use both arc welding equipment and Gas welding equipments. The safety precautions should be taught to them. Practice should be given to maintain the welding equipments. Students should know how to strike the arc, maintaining the arc, current selection for particular thickness and how to obtain various types of flames. They should be trained to do welding of different configurations.

Basic skills in lathe should be given to Diploma Engineers. Exposure to the working principles and various kinds of tools and methods of Turning, Drilling operations should be given.

OBJECTIVES:

- Identify the parts of a center lathe
- Identify the work holding devices
- Set the tools for various operations
- Operate the lathe and Machine a component using lathe
- Identify the tools used in foundry.
- Identify the tools and equipments used in welding
- Prepare sand moulds for different patterns.
- Perform welding operation to make different types of joints.
- Identify the different welding defects.
- Appreciate the safety practices used in welding.

GUIDELINES:

- All the experiments given in the list of experiments should be completed and given for the end semester practical examination.
- In order to develop best skills in handling Instruments/Equipment and taking readings in the practical classes, every two students should be provided with a separate experimental setup for doing experiments in the laboratory.
- The external examiners are requested to ensure that a single experimental question should not be given to more than four students while admitting a batch of 30 students during Board Examinations.

Note: All dimensions in mm

Manufacture and estimate the cost of the job for following exercises by assuming the suitable raw material for the final size of the components.

Note to the faculty :-Last job of the raw material(MS Rod $\text{Ø}32 \times 77\text{mm}$ and MS Rod $\text{Ø}25 \times 77\text{mm}$) to be retain in student wise or batch wise .This may be verifiable at the time of Board Practical Examination by the external examiner.

All linear dimensions in $\pm 0.5\text{mm}$ and All cylindrical dimensions in $\pm 0.2\text{mm}$ tolerance.

1. Lathe

1. Introduction of safety in operating machines.
2. Introduction to lathe and its parts.
3. Introduction to work holding devices and tool holding devices.
4. Types of tools used in lathe work.
5. Types of measuring instruments and their uses.
6. Setting of work and tools.
7. Operation of lathe.
8. Practice on a lathe.

Exercises:

1. Plain turning
2. Step turning
3. Taper turning
4. Knurling
5. Thread cutting
6. Bushing.

2. Welding

- a. Introduction of Safety in welding shop.
- b. Introduction to hand tools and equipments.
- c. Arc and gas welding equipments.
- d. Types of joints.

Exercises:

a. Arc welding

1. Lap joint (Material : 25 mm x 6mm MS flat)
2. Butt joint (Material : 25mm x 6mm MS flat)
3. T- joint (Material : 25mm x 6mm MS flat)
4. Corner joint (Material : 25mm x 6mm MS flat)

b. Gas welding

1. Lap joint (Material : 25 mm x 6mm MS flat)
2. Butt joint (Material : 25mm x 6mm MS flat)
3. T- joint (Material : 25mm x 6mm MS flat)
4. Corner joint (Material : 25mm x 6mm MS flat)
5. Gas cutting : Profile cutting

1. Plain turning

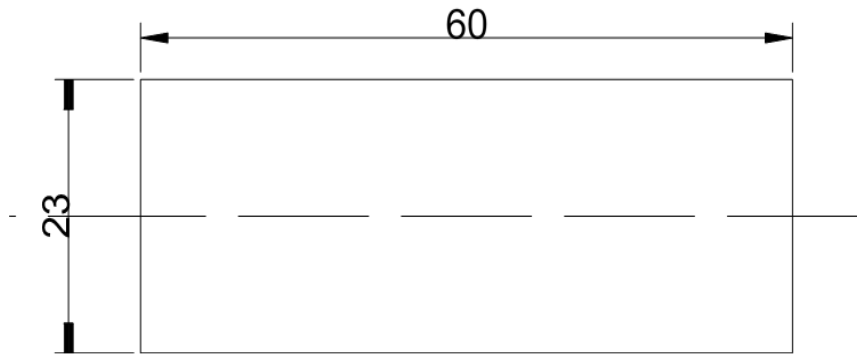

2. Step turning

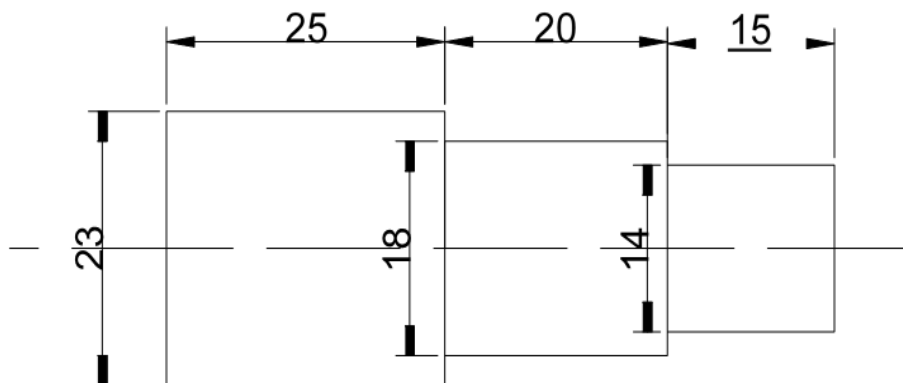

3. Taper turning

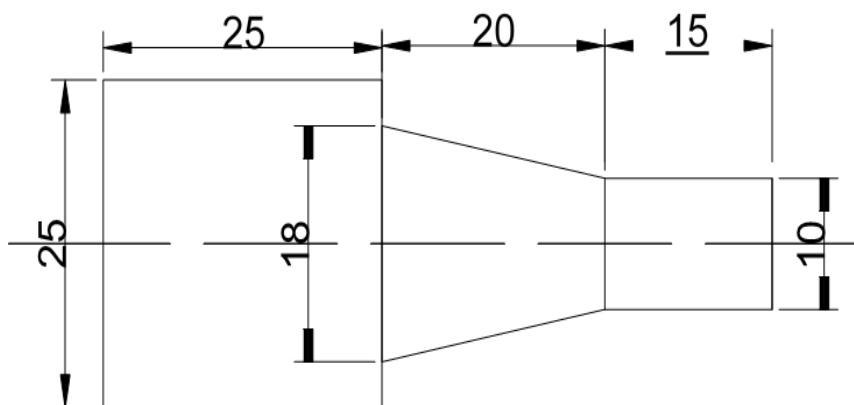

4. Taper turning- multiple turning

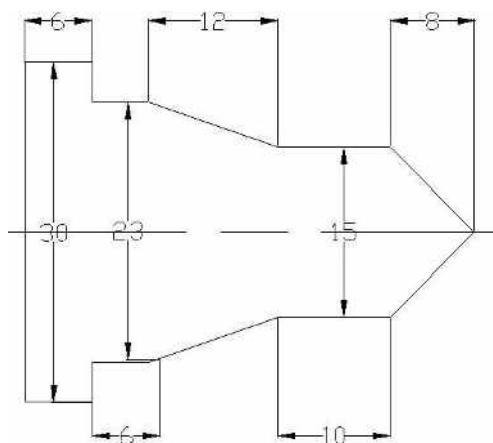

5. Thread cutting

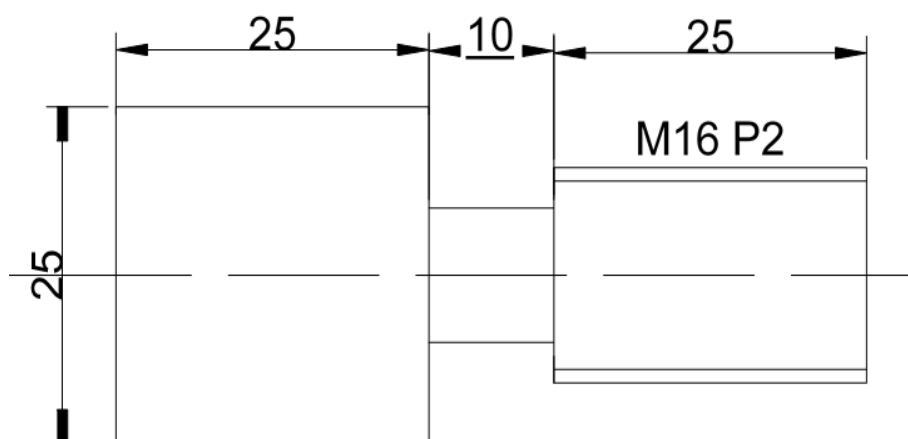

6. Knurling

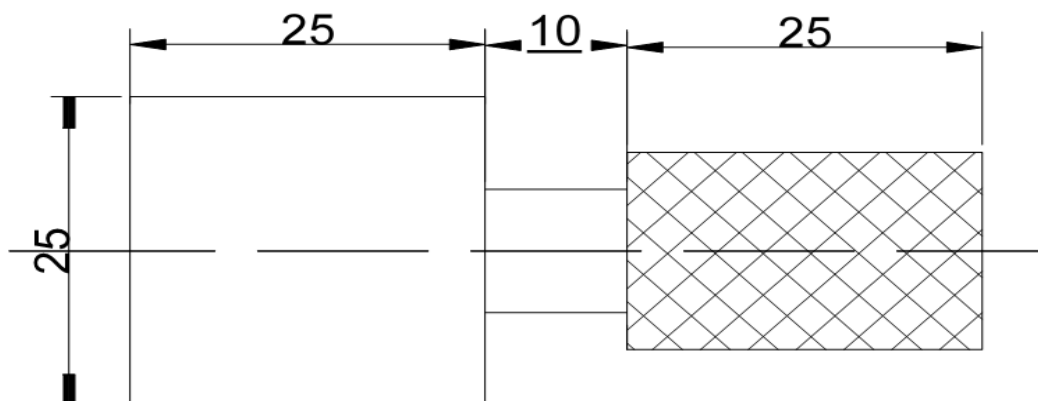

7. Bushing

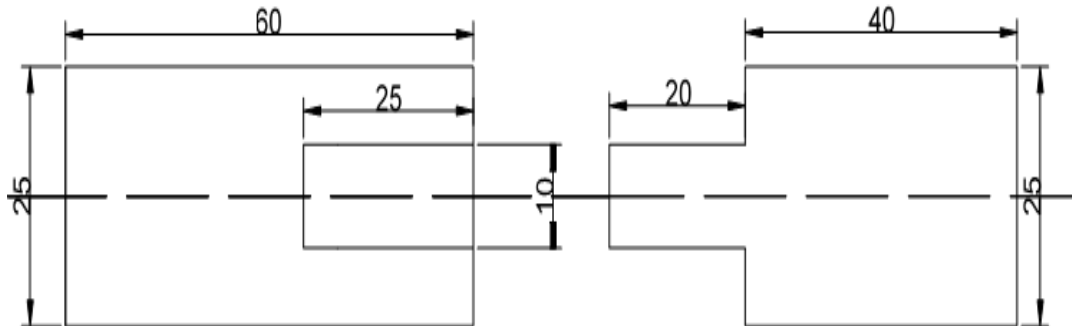

LIST OF EQUIPMENTS AND THE QUANTITY REQUIRED

1. A.C / D.C welding machine	-	1+1set
2. Electrodes with cables	-	1set
3. Earth Clamp with cables	-	1set
4. Leather / Asbestos Apron	-	15
5. Leather / Asbestos hand gloves	-	15
6. Hand Shield	-	15
7. Helmet	-	15
8. Safety goggles	-	15
9. Chipping Hammer	-	5
10. Wire Brush	-	5
11. Tong	-	15
12. Gas welding torch	-	2
13. Gas welding Nozzle set	-	1set
14. Nozzle cleaner set	-	1
15. Oxygen regulator	-	1
16. Acetylene regulator	-	1
17. Oxygen & Acetylene Hose in required length	-	1+1
18. Hose clips	-	4
19. Hose connector	-	4
20. Spark lighter	-	4
21. Water Bucket	-	2
22. Oxygen Cylinder	-	2
23. Acetylene Cylinder	-	2
24. Trolley	-	1

Machines and Instruments:

1. Center Lathe 4 ½ ' Bed length	–	15 No's
2. 4 Jaw / 3 Jaw Chucks	–	required Numbers
3. Chuck key (10 mm x 10 mm size)	–	15 No's
4. Box spanner	–	15 No's
5. Cutting Tool H.S.S ¼ " X ¼ " X 4 " long	–	15 No's
6. Pitch gauge	–	5 Nos
7. Vernier Caliper (0-25 and 25-50)	–	5 nos each
8. Micrometer, Inside and Outside(0-25 and 25-50)	-	5 each
9. Vernier Height Gauge(300mm)	-	1 no
10. Snap gauge	–	1 set
11. Gear tooth Vernier	-	1 No
12. Steel Rule (0-150)	–	15 Nos.
13. Outside and Inside Calipers	-	15 Nos. each
14. Thread gauge	–	5 Nos.
15. Bevel Protractor	–	1 No
16. Jenny Caliper	–	5 Nos.
17. Dial Gauge with Magnetic Stand	–	5 Nos.
18. Marking Gauge	–	10 Nos.
19. Safety Glass	–	15 Nos.

BOARD EXAMINATION

1. Lathe	: 45 marks (2hours)
2. Welding	: 25 marks (1 hour)
3. Viva-voce	: 05 marks
Total	: 75 mark

(All questions By lot Equal distribution in a session)



DIRECTORATE OF TECHNICAL EDUCATION

DIPLOMA IN AGRICULTURAL TECHNOLOGY

III YEAR

M SCHEME

V- SEMESTER

2015-2016 (on wards)

LIFE AND EMPLOYABILITY SKILL PRACTICAL

CURRICULUM DEVELOPMENT CENTRE

STATE BOARD OF TECHNICAL EDUCATION & TRAINING, TAMILNADU

DIPLOMA IN ENGINEERING – SYLLABUS – M Scheme

(Being implemented from the Academic Year 2016-2017 onwards)

Course Name : **All Branches of Diploma in Engineering and Technology and Special Programmes**

Subject Code : **30002**

Semester : **IV /V**

Subject Title : **LIFE AND EMPLOYABILITY SKILLS PRACTICAL**

Teaching and Scheme of Examination:

No. of Weeks per Semester: 15 Weeks

Subject	Instruction		Examination			
	Hours/ Week	Hours/ Semester	Marks			Duration
			Internal assessment	Board Examination	Total	
Life and Employability Skills	4 Hours	60 Hours	25	75	100	3 Hours

Topics and Allocation of Hours:

Sl. No.	Section	No. of Hours
1	Part – A Communication	30
2	Part – B Entrepreneurship, Project Preparation, Productivity, Occupational Safety, Health, Hazard, Quality Tools & Labour Welfare	20
3	Part – C Environment, Global Warming, Pollution	10
TOTAL		60

RATIONALE

Against the backdrop of the needs of the Industries, as well as based on fulfilling the expectations of the Industries, the Diploma Level students have to be trained directly and indirectly in toning up their competency levels. Proficiency in Communication only, equips them with confidence and capacity to cope with the employment. Hence, there is a necessity to focus on these in the curriculum. At the end of the Course, the student is better equipped to express himself in oral and written communication effectively.

SPECIFIC INSTRUCTIONAL OBJECTIVES

- 1. Emphasize and Enhance Speaking Skills**
- 2. Increase Ability to Express Views & Opinions**
- 3. Develop and Enhance Employability Skills**
- 4. Induce Entrepreneurship and Plan for the Future**
- 5. Expose & Induce Life Skills for Effective Managerial Ability**

LIFE AND EMPLOYABILITY SKILLS PRACTICAL

SYLLABUS

Unit	Topics	Activity	Hours
I	Communication, Listening, Training, Facing Interviews, Behavioural Skills	-- instant sentence making – say expressions/phrases-- self- introduction/another higher official in company – describe/explain product – frame questions based on patterns – make sentences based on patterns	30
II	Entrepreneurship, Project Preparation, Marketing Analysis, Support & Procurement	-- prepare an outline of a project to obtain loan from bank in becoming an entrepreneur – prepare a resume	10
III	Productivity – comparison with developed countries, Quality Tools, Circles, Consciousness, Management, House Keeping	-- search in the website -- prepare a presentation – discuss & interact	05
IV	Occupational Safety, Health Hazard, Accident & Safety, First-Aid, Labour Welfare Legislation, Welfare Acts	-- search in the website -- prepare a presentation – discuss & interact	05
V	Environment, Global Warming, Pollution	-- taking down notes / hints – answering questions -- fill in blanks the exact words heard	10

LEARNING STRUCTURE

100

Marks

- Focus more on Speaking & Listening Skills
- Attention less on Reading & Writing Skills
- Apply the skills in fulfilling the Objectives on Focused Topics

a) Listening 25 Marks

1. Deductive Reasoning Skills (taking down notes/hints) 10
2. Cognitive Skills (answering questions) 10
3. Retention Skills (filling in blanks with exact words heard) 05

b) Speaking Extempore/ Prepared 30 Marks

1. Personality/Psychological Skills (instant sentence making) 05
2. Pleasing & Amiable Skills (say in phrases/expressions) 05
3. Assertive Skills (introducing oneself/others) 05
4. Expressive Skills (describe/explain things) 05
5. Fluency/Compatibility Skills (dialogue) 05
6. Leadership/Team Spirit Skills (group discussion) 05

c) Writing & Reading 20 Marks

1. Creative & Reasoning Skills (frame questions on patterns) 05
2. Creative & Composing Skills (make sentences on patterns) 05
3. Attitude & Aim Skills (prepare resume) 05
4. Entrepreneurship Skills (prepare outline of a project) 05

d) Continuous Assessment (Internal Marks) 25 Marks

(search,read, write down, speak, listen, interact & discuss)

1. Cognitive Skills (Google search on focused topics)
2. Presentation Skills& Interactive Skills (after listening, discuss)

Note down and present in the Record Note on any 5 topics 10 Marks

Other activities recorded in the Record note 10 Marks

Attendance 05 Marks

INTERNAL MARKS 25 MARKS

EXTERNAL MARKS AT END EXAMINATION 75 MARKS

MODEL QUESTION

Time: 3 Hours

Maximum Marks: 75

A. LISTENING 25
Marks

1. Listen to the content and take down notes/hints 10
2. Listen to the content and answer the following questions. 10
3. Listen to the content and fill in the blanks the exact words heard. 05

B. SPEAKING 30
Marks

1. Say in a sentence instantly on hearing the word(5 words, one after another). 05
2. Say any five expressions commonly used in communication. 05
3. Imagine, a consultant has come to your department.
 Introduce him to your subordinates. 05
4. Explain/describe the product you are about to launch in the market. 05
5. Speak with your immediate boss about the progress you have made. 05
6. Discuss within the group on the topic of focus in the syllabus. 05

C. WRITING & READING 20
Marks

1. Frame new questions from the pattern given by changing sets of words with your own. 05

a.	When	do	you	return?
b.	How	is	his performance?	
c.	Where	has	the manager	gone?
d.	What	is	the progress	today?
e.	Why	are	the machines	not functioning?

2. Make sentences from the pattern given by changing sets of words with your own. 05

a.	The workers	are	on strike		
b.	The labourers	are paid	well	in this factory	
c.	There	is	a rest room	for the workers	
d.	These	are	the new products	launched	by our company
e.	Almost everyone	come	to the company	on motorbikes	

3. Prepare a resume for the post of Department Manager. 05
4. Prepare an outline of a project to obtain a loan. (Provide headings and subheadings) 05

I. Guidelines for setting the question paper:

A. LISTENING :

ONLY TOPICS related to
POLLUTION /
ENVIRONMENT /
GLOBAL WARMING are to be taken.
These topics are common for all the three types of evaluation.

B. SPEAKING :

1. WORDS of common usage
2. Fragments – expression of politeness, courtesy, cordiality
3. Introduce yourself as an engineer with designation or
Introduce the official visiting your company/department
4. Describe/Explain the product/machine/department
5. Dialogue must be with someone in the place of work.
6. Group of six/eight
Discuss the focused topic prescribed in syllabus

C. WRITING & READING:

1. Provide five different structures.
Students are to substitute at least one with some other
word/words
2. Provide five different structures.
Students are to substitute at least one with some other
word/words
3. Provide some post related to industries.
4. Outline of the project (skeleton/structure)
Only the various headings and subheadings
Content is not needed

II. Guidelines for recording the material on the Focused Topics in the Record note.

Write in the record note, **on any five topics**, from the list of topics given below. **10 Marks**
(5 topics x 10 marks = 50 marks. Thus, the **Average of 5 topics is 10 Marks**)

1. Productivity in Industries – Comparison with developed countries
2. Quality Tools, Quality Circles and Quality Consciousness
3. Effective Management

4. House Keeping in Industries
5. Occupational Safety and Hazard
6. Occupational Accident and First Aid
7. Labour Welfare Legislations
8. Labour Welfare Acts and Rights
9. Entrepreneurship
10. Marketing Analysis, Support and Procurement

LABORATORY REQUIREMENT:

1. An echo-free room
2. Necessary furniture and comfortable chairs
3. A minimum of two Computers with internet access
4. A minimum of two different English dailies
5. A minimum of Three Mikes with and without cords
6. Colour Television (minimum size – 29”)
7. DVD/VCD Player with Home Theatre speakers
8. Smart board
9. Projector

Suggested Reading:

1. Production and Operations Management by S.N. Chary, TMH
2. Essentials of Management by Koontz & Wehrich, TMH
3. Modern Production / Operations Management by E.S. Buffa and R.K. Sarin, John Wiley & Sons
4. Production Systems: Planning, Analysis and Control by J.L. Riggs, 3rd ed., Wiley.
5. Production and Operations Management by A. Muhlemann, J. Oakland and K. Lockyer, Macmillan
6. Operations Research - An Introduction by H.A. Taha, Prentice Hall of India
7. Operations Research by J.K. Sharma, Macmillan
8. Business Correspondence & Report Writing by R.C. Sharma and K. Mohan, TMH
9. How to prepare for Group Discussion & Interview (With Audio Cassette) by Prasad, TMH
10. Spoken English – A self-learning guide to conversation practice (with Cassette)
11. Introduction to Environmental Engineering by Mackenzie, L. Davis and A. David, Cornwell, McGrawHill, 3rd Ed.
12. Environmental Engineering by Peary, Rowe and Tchobanoglous, McGrawHill
13. Total Quality Management – An Introductory Text by Paul James, Prentice Hall
14. Quality Control and Applications by Housen & Ghose
15. Industrial Engineering Management by O.P. Khanna

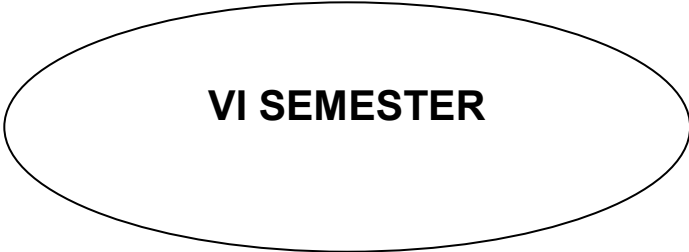
The text "VI SEMESTER" is centered within a black-outlined oval shape.

VI SEMESTER



DIRECTORATE OF TECHNICAL EDUCATION

DIPLOMA IN AGRICULTURAL TECHNOLOGY

III YEAR

M SCHEME

VI SEMESTER

2015-2016(on wards)

INDUSTRIAL ENGINEERING AND MANAGEMENT

CURRICULUM DEVELOPMENT CENTRE

M-SCHEME

(Implemented from the Academic year 2015-2016 onwards)

Course Name : DIPLOMA IN AGRICULTURAL TECHNOLOGY
Course Code : 1222
Subject Code : 32061
Semester : VI
Subject Title : Industrial Engineering and Management

TEACHING AND SCHEME OF EXAMINATIONS:

No. of Weeks per Semester: 15 Weeks

Subject	Instructions		Examination			
	Hours/ Week	Hours/ Semester	Marks		Duration	
Industrial Engineering and Management	6	90	Internal Assessment	Board Examination	Total	3 Hours
			25	75	100	

Topics and Allocation of Hours:

UNIT NO.	TOPIC	HOURS
I	PLANT ENGINEERING AND PLANT SAFETY	17
II	WORK STUDY, METHOD STUDY AND WORK MEASUREMENT	17
III	PRODUCTION PLANNING AND QUALITY CONTROL	17
IV	PRINCIPLES, PERSONNEL MANAGEMENT AND ORGANIZATIOAL BEHAVIOR:	16
V	FINANCIAL AND MATERIAL MANAGEMENT	16
	REVISION AND TEST	7
	TOTAL	90

RATIONALE:

In the Indian Economy, Industries and Enterprises always find prominent place. After globalization, the students should be trained not only in manufacturing processes but also in managing activities of industries. The knowledge about plant, safety, work study techniques, personnel management and financial management will definitely mould the students as managers to suit the industries.

OBJECTIVES:

- To study the different types of layout.
- To study the safety aspects and its impacts on an organization.
- To study different work measurement techniques.
- To study production planning and control and its functions.
- To study basic and modern management techniques.
- To study the staff selection procedure and training of them.
- To study capital and resources of capital.
- To study inventory control system.
- To study about organization and it's behavior.

DETAILED SYLLABUS

Contents: Theory

UNIT	NAME OF THE TOPIC	HOURS
I	PLANT ENGINEERING AND PLANT SAFETY Plant Engineering : Plant – Selection of site of industry – Plant layout – Principles of a good layout – types – process, product and fixed position – techniques to improve layout – Principles of material handling equipment – Plant maintenance – importance – Break down maintenance, preventive maintenance and scheduled maintenance. Plant Safety: Importance –accident-causes and cost of an accident-accident proneness-prevention of accidents-Industrial disputes-settlement of Industrial disputes-Collective bargaining, conciliation, Mediation, arbitration-Indian Factories Act 1948 and its provisions related to health, welfare and safety.	17
II	WORK STUDY, METHOD STUDY AND WORK MEASUREMENT Work Study: Productivity – Standard of living – method of improving productivity – Objectives – Importance of good working conditions. Method Study: Definition – Objectives – Selection of a job for method study –Basic procedure for conduct of method study – Tools used – Operation process chart, Flow process chart, two handed process chart, Man machine chart, String diagram and flow diagram. Work Measurement: Definition – Basic procedure in making a time study – Employees rating factor – Application of time allowances – Rest, Personal, Process, Special and Policy allowances – Calculation of standard time – Problems – Basic concept of production study – Techniques of work measurement-Ratio delay study, Synthesis from standard data, analytical estimating and Pre determined Motion Time System (PMTS).	17
III	PRODUCTION PLANNING AND QUALITY CONTROL Production Planning and Control: Introduction – Major functions	17

of production planning and control – Pre planning – Methods of forecasting – Routing and scheduling – Dispatching and controlling – Concept of Critical Path Method (CPM)-Description only. Production – types-Mass production, batch production and job order production- Characteristics – Economic Batch Quantity (EBQ) – Principles of product and process planning – make or buy decision.

Quality Control: Definition – Objectives – Types of inspection – First piece, Floor and centralized inspection – Advantages and disadvantages. Quality control – Statistical quality control – Types of measurements – Method of variables – Method of attributes – Uses of X, R, p and c charts – Operating Characteristics curve (O.C curve) – Sampling inspection – single and double sampling plan – Concept of ISO 9001:2008 Quality Management System Registration Certification procedure – Benefits of ISO to the organization.

IV PRINCIPLES, PERSONNEL MANAGEMENT AND ORGANIZATIONAL BEHAVIOR:

16

Principles of Management: Definition of management – Administration - Organization – F.W. Taylor's and Henry Fayol's Principles of Management – Functions of Manager – Directing – Leadership -Styles of Leadership – Qualities of a good leader – Motivation – Positive and negative motivation --Modern management techniques- Just In Time – Total Quality Management (TQM) – Quality circle – Zero defect concept – 5S Concept- Management Information Systems – Strategic management – SWOT Analysis --Business Process Re-engineering (BPR) – Enterprises Resource Planning (ERP) –Supply Chain Management (SCM) – Activity Based Management (ABM) – Global Perspective – Principles and brief description.

Personnel Management: Responsibility of human resource management – Selection procedure – Training of workers – Apprentice training – On the job training and vestibule school training – Job evaluation and merit rating – objectives and

importance – wages and salary administration – Components of wages – Wage fixation – Type of wage payment – Halsey's 50% plan, Rowan's plan and Emerson's efficiency plan – Problems.

Organizational behavior: Definition – organization--Types of Organization – Line, Staff, Taylor's Pure functional types – Line and staff and committee type –Organizational Approaches, individual behavior—causes—Environmental effect—Behavior and Performance, Perception-organizational implications.

V FINANCIAL AND MATERIAL MANAGEMENT

16

Financial Management: Fixed and working capital – Resources of capital – shares preference and equity shares – debentures – Type of debentures – Public deposits, Factory costing – direct cost – indirect cost – Factory overhead – Selling price of a product – Profit – Problems. Depreciation – Causes – Methods - Straight line, sinking fund and percentage on diminishing value method – Problems.

Material management: Objectives of good stock control system – ABC analysis of inventory – Procurement and consumption cycle – Minimum Stock, Lead Time, Reorder Level-Economic order quantity problems – supply chain management – Introduction – Purchasing procedure – Store keeping – Bin card.

Text Books :

- 1) Industrial Engineering and Management, O.P. Khanna, Revised Edition Publications (P) Ltd – 2004, 67/4 Madras House, Daryaganj, New Delhi – 110002.
- 2) Engineering Economics and Management, T.R. Banga & S.C. Sharma, McGraw Hill Edition. 2 – 2001, New Delhi.
- 3) Herald Koontz and Heinz Weihrich, 'Essentials of Management', McGraw Hill Publishing Company, Singapore International Edition. Latest

Reference Books :

- 1) Management, A global perspective, Heinz Wehrich, Harold Koontz, 10th Edition, McGraw Hill International Edition.Latest.
- 2) Essentials of Management, 4th Edition, Joseph L.Massie, Prentice-Hall of India, New Delhi 2004.
- 3) S.Chandran,Organizational Behaviours,Vikas Publishing House Pvt. Ltd. Latest
- 4) M.Govindarajan and S.Natarajan,Principles of Management,Prentce Hall of India Pvt.Ltd.New Delhi.Latest.



DIRECTORATE OF TECHNICAL EDUCATION

DIPLOMA IN AGRICULTURAL TECHNOLOGY

III YEAR

M SCHEME

VI SEMESTER

2015-2016 (on wards)

COMPUTER AIDED DESIGN AND MANUFACTURING

CURRICULUM DEVELOPMENT CENTRE

M-SCHEME

(Implements from the Academic year 2015-2016 onwards)

Course Name : DIPLOMA IN AGRICULTURAL TECHNOLOGY
Course Code : 1222
Subject Code : 32062
Semester : VI
Subject Title : COMPUTER AIDED DESIGN AND MANUFACTURING

TEACHING AND SCHEME OF EXAMINATIONS:

No. of weeks per semester: 15 Weeks

Subject	Instructions		Examination			Duration
	Hours / Week	Hours / Semester	Marks			
Computer Aided Design and Manufacturing	5	75	Internal Assessment	Board Examination	Total	3 Hrs
			25	75	100	

Topics and Allocation of Hours:

Unit	Topics	Hours
I	COMPUTER AIDED DESIGN	14
II	COMPUTER AIDED MANUFACTURING	14
III	CNC PROGRAMMING, RAPID PROTOTYPING	14
IV	COMPUTER INTEGRATED MANUFACTURING, FLEXIBLE MANUFACTURING SYSTEMS, AUTOMATIC GUIDED VEHICLE, ROBOT	13
V	CONCURRENT ENGINEERING, QUALITY FUNCTION DEPLOYMENT, PRODUCT DEVELOPMENT CYCLE, AUGMENTED REALITY.	13
	REVISION AND TEST	7
	Total	75

RATIONALE:

As per the latest requirements in the Industries this enables to learn the assistance of computer in the field of design and manufacturing areas. It's able to learn the latest manufacturing concepts of in the shop floors and manufacturing methods like RPT. They are able to know about the CNC programming techniques are included.

OBJECTIVES:

- Understand the concept and requirement of the integration of the design and manufacturing.
- Acquire knowledge about the computer assistance in the design process and analysis.
- Understand the concepts of manufacturing with computer assistance in the shop floor.
- Understand the principle of latest manufacturing machines like RPT.
- Acquire the knowledge in the material handling equipment and robot.
- Understand the Computer Integrated Manufacturing and FMS.
- Study of Concurrent Engineering and its tools and Augmented Reality.

**32064 COMPUTER AIDED DESIGN AND MANUFACTURING
DETAILED SYLLABUS**

Contents: Theory

Unit	Name of the Topic	Hours
I	COMPUTER AIDED DESIGN Computer Aided Design: Introduction – definition – Shigley’s design process – Ohsguga Model - CAD activities – benefits of CAD - CAD software packages. Transformations: 2D & 3D transformations – translation, scaling, rotation and concatenation. Geometric modelling: Techniques - Wire frame modelling – applications – advantages and disadvantages. Surface modelling – types of surfaces – applications – advantages and disadvantages – Solid modelling – entities – advantages and disadvantages – Boolean operations - Boundary representation – Constructive Solid Geometry – Comparison. Graphics standard: Definition – Need - GKS – OpenGL - IGES – DXF. Finite Element Analysis: Introduction – Development - Basic steps – Advantage.	14
II	COMPUTER AIDED MANUFACTURING Computer Aided Manufacturing: Introduction - Definition – functions of CAM – benefits of CAM. Group technology: Part families - Parts classification and coding - coding structure – Optiz system, MICLASS system and CODE System. Process Planning: Introduction – Computer Assisted Process Planning (CAPP) – Types of CAPP - Variant type, Generative type – advantages of CAPP. Production Planning and Control (PPC): Definition – objectives - Computer Integrated Production management system – Master Production Schedule (MPS) – Capacity Planning – Materials	14

Requirement Planning (MRP) – Manufacturing Resources Planning (MRP-II) – Shop Floor Control system (SFC) - Just In Time manufacturing philosophy (JIT) - Introduction to Enterprise Resources Planning (ERP).

III CNC PROGRAMMING, RAPID PROTOTYPING 14

CNC PART PROGRAMMING: Manual part programming - coordinate system – Datum points: machine zero, work zero, tool zero - reference points - NC dimensioning – G codes and M codes – linear interpolation and circular interpolation - CNC program procedure - sub-program – canned cycles - stock removal – thread cutting – mirroring – drilling cycle – pocketing.

Rapid prototyping: Classification – subtractive – additive – advantages and applications - materials. Types - Stereo lithography (STL) – Fused deposition model (FDM) – Selective laser sintering (SLS) - three dimensional printing (3D) – Rapid tooling.

IV COMPUTER INTEGRATED MANUFACTURING, FLEXIBLE MANUFACTURING SYSTEMS, AUTOMATIC GUIDED VEHICLE, ROBOT 13

CIM: Introduction of CIM – concept of CIM - evolution of CIM – CIM wheel – Benefits – integrated CAD/CAM.

FMS: Introduction – FMS components – FMS layouts – Types of FMS: Flexible Manufacturing Cell (FMC) – Flexible Turning Cell (FTC) – Flexible Transfer Line (FTL) – Flexible Machining System (FMS) – benefits of FMS - introduction to intelligent manufacturing system.

AGV: Introduction – AGV - working principle – types – benefits.

ROBOT: Definition – robot configurations – basic robot motion – robot programming method – robotic sensors – end effectors – mechanical grippers – vacuum grippers - Industrial applications of Robot: Characteristics - material transfer and loading – welding - spray coating - assembly and inspection.

V CONCURRENT ENGINEERING, QUALITY FUNCTION DEPLOYMENT, PRODUCT DEVELOPMENT CYCLE, 13

AUGMENTED REALITY.

Concurrent Engineering: Definition – Sequential Vs Concurrent engineering – need of CE – benefits of CE.

Quality Function Deployment (QFD): Definition – House of Quality (HOQ) – advantages – disadvantages. Steps in Failure Modes and Effects Analysis (FMEA) – Value Engineering (VE) – types of values – identification of poor value areas – techniques – benefits. Guide lines of Design for Manufacture and Assembly (DFMA).

Product Development Cycle: Product Life Cycle - New product development processes.

Augmented Reality (AR) – Introduction - concept – Applications.

Text Books :

- 1) CAD/CAM/CIM , R.Radhakrishnan, S.Subramanian, New Age International Pvt. Ltd.
- 2) CAD/CAM , Mikell P.Groover, Emory Zimmers, Jr.Prentice Hall of India Pvt., Ltd.

Reference Books :

- 1) CAD/CAM Principles and Applications, Dr.P.N.Rao, Tata Mc Graw Hill Publishing Company Ltd.
- 2) CAD/CAM, Ibrahim Zeid, Mastering Tata McGraw-Hill Publishing Company Ltd., New Delhi.
- 3) Automation, Production Systems, and Computer-Integrated Manufacturing, Mikell P. Groover, Pearson Education Asia.
- 4) Computer control of manufacturing systems, Yoram Koren, McGraw Hill Book.



DIRECTORATE OF TECHNICAL EDUCATION

DIPLOMA IN AGRICULTURAL TECHNOLOGY

III YEAR

M SCHEME

VI SEMESTER

2015-2016 (on wards)

SUGARCANE CROP PRODUCTION

CURRICULUM DEVELOPMENT CENTRE

M – SCHEME

(Implements from the academic year 2015-2016 onwards)

Course Name : DIPLOMA IN AGRICULTURAL TECHNOLOGY
Course Code : 1222
Subject Code : 32381
Semester : VI
Subject Title : **SUGARCANE CROP PRODUCTION**

TEACHING AND SCHEME OF EXAMINATION:

No of weeks per semester: 15 Weeks

Subject	Instruction		Examination			Duration
	Hours /week	Hours /Semester	Marks			
			Internal Assessment	Board Examination	Total	
SUGARCANE CROP PRODUCTION	5 Hrs	75 Hrs	25	75	100	3 Hrs

Topics and Allocation of Hours:

Unit No	Topic	Hours
I	INTRODUCTION – SUGARCANE IN INDIA	14
II	AGRONOMY OF SUGARCANE	14
III	CROP PROTECTION	14
IV	MECHANIZATION IN SUGARCANE CULTIVATION	13
V	EXTENSION METHODS	13
	REVISION & TEST	7
	Total	75

RATIONALE:

Sugarcane is one of the major crops in India. It requires less water than any other cash crops. The byproduct of sugarcane is alcohol which can be blended with petroleum product. This earns a good junk of foreign exchange.

OBJECTIVES:

- To study History and role of sugarcane in Indian Economy.
- To understand the potentials of sugar industry.
-
- To know the agro climatic condition of sugarcane crop.
- To know the field preparation and agronomical practice required for sugarcane crop.
- To understand the ratoon management practices
-
- Management of weeds, pest and disease
- To know the machines used in sugarcane crop farming
- To get firsthand experience in extension activities of sugarcane cultivation

32381 SUGARCANE CROP PRODUCTIONS

DETAILED SYLLABUS

Contents : Theory

Unit	Name of the topic	Hours
I	INTRODUCTION – SUGARCANE IN INDIA. History – role of Sugarcane in the national economy – Area Production and Productivities – Growth of sugar Industry – Sugarcane Research – Sugar factories – Sugar cane regions – Sugarcane by - products and scope for diversification of sugar industry .	14 Hrs
II	Agronomy of Sugarcane Sugarcane plant – Sugarcane growing seasons – varieties – land Preparation – soil fertility management – nursery – seed material – planting systems – intercropping – irrigation – manuring – cultural operations -harvesting – sugar recovery – ratoon management operation .	13HRS
III	Crop protection Weed management – disease management – pest management – Management of sugarcane under stressed conditions.	14 Hrs
IV	Mechanization in sugarcane cultivation Field preparation equipments – planter – intercultural operation implements – ratoon management operations implements – sprayers – mechanical cane harvesters.	13 Hrs
V	Extension methods Extension – Definition – Extension methods – direct contacts- Farm and home visits - Office calls – Personal letters – Observation plots- Result demonstration. Group contacts – Method demonstration - General meetings – Field trips. Mass contacts – Publications – Circular letters – News articles – Radio – Television. Field Visits – Factory Visits.	14 Hrs

Reference Book :

1. Sugarcane Cultivation by B.Sundara Vikas Publishing House Pvt Ltd, 576, Majith road, Janpura, New Delhi.
2. Sugarcane technologies by K.Mohan Naidu, Kalakathir Achagam, Coimbatore
3. Technologies to improve Sugarcane Productivity by T.Rajulla Gowdari N. Vijaya Nair, Director, Sugarcane breeding institute, CBE.
4. Sugar cane at a glance by A.K. Srivastavs, International book distributing co., Chaman studio building ,Charbagh, Lucknow – 226004 UP, India.
5. Extension education by A.Adivi Reddy, Shree Lakshmi Press, Bapatla – 522101 Guntur (District) AP, India.



DIRECTORATE OF TECHNICAL EDUCATION

DIPLOMA IN AGRICULTURAL TECHNOLOGY

III YEAR

M SCHEME

VI SEMESTER

2015-2016(on wards)

DAIRY ENGINEERING

CURRICULUM DEVELOPMENT CENTRE

M – SCHEME

(Implements from the academic year 2015-2016 onwards)

Course Name : DIPLOMA IN AGRICULTURAL TECHNOLOGY
Course Code : 1222
Subject Code : 32382
Semester : VI
Subject Title : DAIRY ENGINEERING

TEACHING AND SCHEME OF EXAMINATION:

No of weeks per semester: 15 Weeks

Subject	Instruction		Examination			Duration
	Hours /week	Hours /Semesters	Marks			
			Internal Assessment	Board Examination	Total	
Dairy Engineering	5 Hrs	75 Hrs	25	75	100	3 Hrs

Topics and Allocation of Hours:

Unit No	Topic	Hours
I	MILK AND ITS PROPERTIES	14
II	MILK COLLECTION AND HANDLING	13
III	QUALITY EVALUATION	14
IV	PROCESSING OF MILK	14
V	SPECIAL MILKS AND MILK PRODUCTS	13
	REVISION & TEST	7
	Total	75

RATIONALE:

The very need of the hour today in Agricultural Engineering and Technology is food processing. Only well processed items are edible and eligible not only for current use but also for storage for future requirements. So it is very essential for the students of this discipline to know about the technology of food processing. The technology not only provides defect free high quality and nutritious food items, but also enables storing of items for long time without any degradation in quality and nutritive values.

The knowledge of the processing methods can meet the demand of the items during some serious situation like off seasons, natural calamity periods and the like. It also can help the students to become entrepreneur in this field. The knowledge is essential to avoid appreciable wastage and spoilage of valuable food items and get notable foreign exchange by exporting.

OBJECTIVES:

- To understand the various properties of milk.
- To understand the ways of collection and handling of milk.
- To know about the quality of milk and its testing.
- To know about the various processing in milk.
- To know the various products in milk and types of milk.
- To understand milk food processing and various types of Milk.

32382 DAIRY ENGINEERING

DETAILED SYLLABUS

Content: Theory

Unit	Name of topic	Hours
I	MILK AND ITS PROPERTIES Milk-definition- composition of milk- major constituents- minor constituents- physicochemical properties of milk- the physical state- acidity and pH of milk- specific gravity- boiling point- freezing point- refractive index- viscosity- colour and flavor.	14
II	MILK COLLECTION AND HANDLING: Procurement of milk- pricing of milk- chilling plant- transportation- receiving milk at dairy plant,	13
III	QUALITY EVALUATION: Organoleptic tests- appearance- sedimentation- acidity- lactometer reading- COB test- alcohol test- sampling- lab test for milk- detection of adulteration- Bacteriological quality- direct microscopic count- standard plate count- coliform test.	14
IV	PROCESSING OF MILK: Receiving milk- Filtration/clarification- Standardization- Pearson's square method- problems- Pasteurization- Sterilization- homogenization- bottling/ packing- methods of pasteurization- HTST- batch type/ holding pasteurization- IN-bottle pasteurization- Ultra-high temperature short time pasteurization (UHT)- storage and distribution.	14
V	SPECIAL MILKS AND MILK PRODUCTS: Standardized milk- toned milk- double toned milk- homogenized milk- reconstituted milk- recombined milk- filled milk—condensed milk- flavoured milk. Cream- cream separation- cheese- preparation- ice cream preparation- milk powder preparation.	13

Reference books:

1. Milk Production and Processing By C.Ibraheem Kutty and Sheeba Khamer – Daya Publishing House, N.Delhi-110035
2. Outlines of Dairy Technology – by Sukumar De, Oxford University Press
3. Milk and milk products – by Clarence Henry Eckles, Willes Barnes Combs, Harold Macy Tata Mc Graw- Hills Publishing Company Ltd, N.Delhi



DIRECTORATE OF TECHNICAL EDUCATION

DIPLOMA IN AGRICULTURAL TECHNOLOGY

III YEAR

M SCHEME

VI SEMESTER

2015-2016(on wards)

MANUFACTURING ENGINEERING

CURRICULUM DEVELOPMENT CENTRE

M – SCHEME

(Implements from the academic year 2015-2016 onwards)

(Implements from the academic year 2015-2016 onwards)

Course Name : DIPLOMA IN AGRICULTURAL TECHNOLOGY
Course Code : 1222
Subject Code : 32383
Semester : VI
Subject Title : **MANUFACTURING ENGINEERING**

TEACHING AND SCHEME OF EXAMINATION:

No of weeks per semester: 15 Weeks

Subject	Instruction		Examination			Duration
	Hours /week	Hours /Semesters	Marks			
Manufacturing Engineering	5 Hrs	75 Hrs	Internal Assessment	Board Examination	Total	3 Hrs
			25	75	100	

Topics and Allocation of Hours:

Unit No	Topic	Time (Hrs)
I	FOUNDRY AND HEAT TREATMENT OF FERROUS METALS	14
II	FORGING AND WELDING	13
III	MACHINE TOOL AND MACHINING PROCESS	14
IV	MILLING AND GRINDING MACHINES	13
V	PRESS WORK & METAL WORK FINISHING	14
	Test & revision	7
	Total	75

RATIONALE:

The last one decade has witnessed a Phenomenal growth in manufacturing of Agro based Machineries and Equipments. Such machineries are being used extensively in all rural areas in farming operations like Ploughing, Harrowing, Planting, Harvesting etc., Now, Farmers are going with mechanized Agriculture., at various stages of cultivation of food grains, Sugarcane etc.

It is very important to carry out service and repairs of such machineries even at rural areas; which has necessitated the Diploma Engineers to get to know with in-depth study on heat treatment of ferrous metals, welding, grinding processes in addition to the common conventional machine tools.

Accordingly the syllabus is revised to fulfill the above requirements by a Diploma Engineer in the field of Agricultural Engineering and also for his career development as mechanically oriented Agricultural Engineer.

OBJECTIVES:

- Acquire knowledge about types of pattern, casting and moulding.
- Explain hot working and cold working processes.
- Describe the various casting processes.
- Appreciate the safety practices used in welding.
- Explain the working of a lathe and its parts.
- Describe the functioning of various types of drilling machines.
- Explain the working of shaping and milling machines.
- Classify the different types of grinders and grinder wheels.
- Explain the various types of metal work finishing.
- Explain the different types of press and press working operations.

32383 MANUFACTURING ENGINEERING

DETAILED SYLLABUS

Contents : Theory

Unit	Name of the Topic	Hours
I	FOUNDRY & HEAT TREATMENT OF FERROUS METALS Pattern – Pattern material – Types of Pattern – Pattern allowances – Cores – Types – Moulding – Moulding tools and boxes – Moulding sand – Properties – Preparation of green sand and dry sand moulds – Furnaces – Cupola and Crucible - Casting – Die casting – Malleable and chilled castings – Applications – Advantages, Disadvantages and limitations – Heat treatment of metals – annealing, hardening, Tempering – Surface heat treatment – types of case hardening – advantages – applications.	14 Hrs
II	FORGING & WELDING Forging – cold working, Hot working, cold rolling , Hot rolling – classification of forging – smith forging – drop forging, machine forging, press forging, roll forging – advantages, disadvantages and Applications – Welding – Types of welding – welding equipment, Arc and Gas welding, advantages, disadvantages and applications - Flame cutting, soldering and brazing techniques – Advantages and applications, Types of welded joints – welding defects and testing of welded joints.	13 Hrs
III	MACHINE TOOLS AND MACHINING PROCESS Lathe, types of lathe, specification of lathe, Centre lathe, Parts of a lathe – operations performed in a lathe – Taper turning and thread cutting operations only – Drilling machine – Types, Radial drilling machine, operation done on drilling. Shaper – principle of operation of a shaping machine – specifications – standard shaper – construction, - Quick return mechanism in shaper – Feed Mechanism.	14 Hrs

IV	<p>MILLING AND GRINDING MACHINES</p> <p>Milling Machine – Principle of operation – Types of Milling Machine – plain, Universal and vertical milling machines – Construction and working – work holding devices – Tools, Tool holding devices – Milling cutters – Types – Milling process – specification of a milling machine.</p> <p>Grinding Machines – Surface Grinder, Cylindrical grinder, - Centreless Grinders – Advantages, limitations – Standard marking system of grinding wheels, selection of grinding wheels, Glazing and loading of wheels. Dressing and truing of grinding wheel – wheel balancing and mounting of grinding wheels.</p>	13Hrs
V	<p>PRESS WORK AND METAL WORK FINISHING</p> <p>Press working – types of presses – OBI press, adjustable bed press – Driving mechanism – Types – Hydraulic presses – comparison of Mechanical and hydraulic presses – Principle of operation and specification, capacity of a press, press tools and accessories – press Working operations – Bending and shearing operation. Metal work finishing – cleaning, degreasing, sand blasting, acid pickling, coating – anodizing, galvanizing, painting, metal spraying.</p>	14 Hrs

Reference Book:

1. Elements of workshop technology, Vol. I & II S.K Hajra choudhury
S.K. Bose and A.K. Hajara choudhury
2. Production technology R. K. Jain.
3. Workshop technology part I & II W.B.J. Chapman
4. Foundry Engineering T.R. Banga, R.L. Agarwal, T.Manghnani.



DIRECTORATE OF TECHNICAL EDUCATION

DIPLOMA IN AGRICULTURAL TECHNOLOGY

III YEAR

M SCHEME

VI SEMESTER

2015-2016 (on wards)

**COMPUTER AIDED DESIGN AND MANUFACTURING
PRACTICAL**

CURRICULUM DEVELOPMENT CENTRE

M-SCHEME

(Implements from the Academic year 2015-2016 onwards)

Course Name : DIPLOMA IN AGRICULTURAL TECHNOLOGY
Course Code : 1222
Subject Code : 32064
Semester : VI
Subject Title : COMPUTER AIDED DESIGN AND MANUFACTURING PRACTICAL

TEACHING AND SCHEME OF EXAMINATIONS:

No. of Weeks per Semester: 15 Weeks

Subject	Instructions		Examination			Duration
	Hours/ Week	Hours/ Semester	Marks			
Computer Aided Design And Manufacturing Practical	6	90	Internal Assessment	Board Examination	Total	3 Hrs
			25	75	100	

OBJECTIVES:

- Study of parametric modeling.
- Understand the part modeling and assembly of parts
- Create the views of the solid model and parts list.
- Study the working principle of CNC machines
- Study the datum points and offsets.
- Differentiate incremental System with absolute system
- Study the simulation software package.
- Write program and simulate in the Lathe software and Milling software.
- Prepare a part program, edit and execute in CNC Turning centre.
- Prepare a part program, edit and execute in CNC Machining centre.
- Produce components in the CNC Turning centre and CNC Machining centre.

PART A: Solid modeling (30 Hrs.)

Introduction

Part modelling - Datum Plane – constraint – sketch – dimensioning – extrude – revolve – sweep – blend – protrusion – extrusion – rib – shell – hole – round – chamfer – copy – mirror – assembly – align – orient.

Exercises

3D Drawing

1. Geneva Wheel
2. Bearing Block
3. Bushed bearing
4. Gib and Cotter joint
5. Screw Jack
6. Connecting Rod

Note: Print the orthographic view and sectional view from the above assembled 3D drawing.

PART B: CNC Programming and Machining (45 Hrs.)

Introduction:

1. Study of CNC lathe, milling.
2. Study of international standard codes: G-Codes and M-Codes
3. Format – Dimensioning methods.
4. Program writing – Turning simulator – Milling simulator, IS practice – commands menus.
5. Editing the program in the CNC machines.
6. Execute the program in the CNC machines.

Exercises

Note: Print the part program from the simulation software and make the component in the CNC machine.

CNC Turning Machine

Material: M.S / Aluminum / Acrylic fibre / Plastic

1. Using Linear and Circular interpolation - Create a part program and produce component in the Machine.

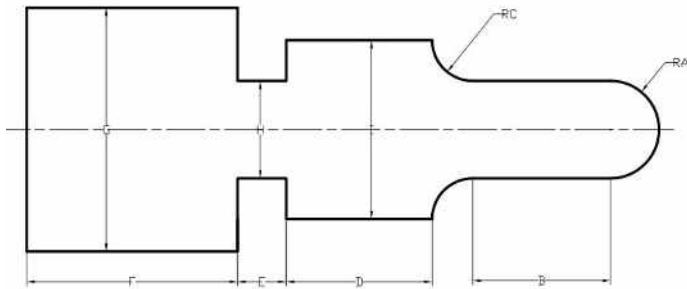

2. Using Stock removal cycle – Create a part program for multiple turning operations and produce component in the Machine.

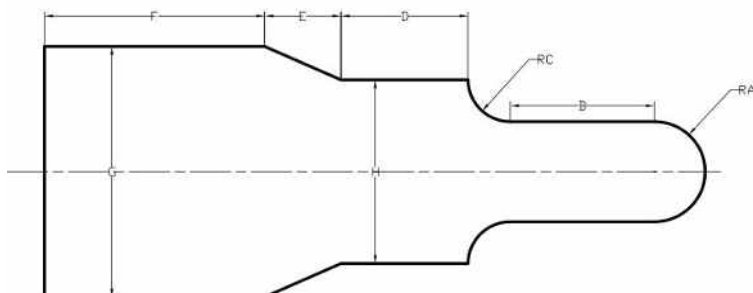

3. Using canned cycle - Create a part program for thread cutting, grooving and produce component in the Machine.

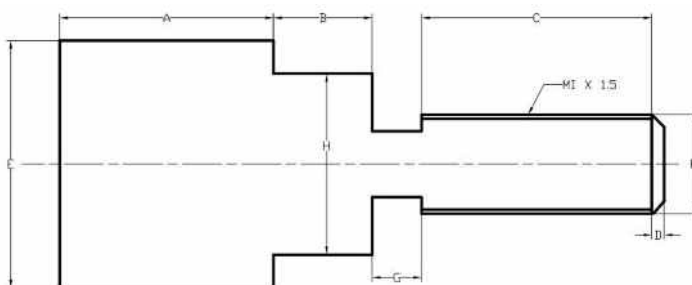

CNC Milling Machine

Material: M.S / Aluminum / acrylic fibre / plastic

4. Using Linear interpolation and Circular interpolation – Create a part program for grooving and produce component in the Machine.

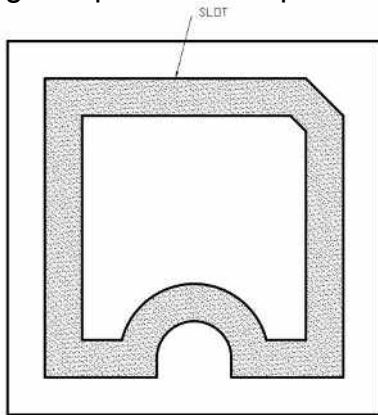

5. Using canned cycle - Create a part program for drilling, tapping, counter sinking and produce component in the Machine.

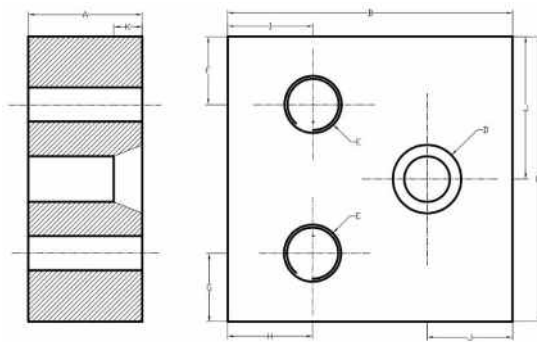

6. Using subprogram - Create a part program and produce component in the Machine.

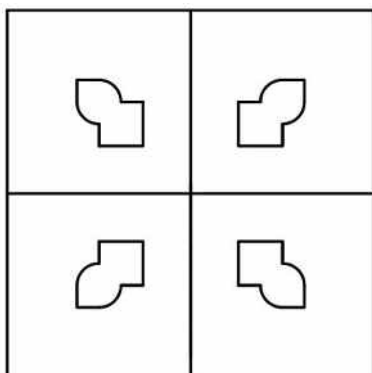

Reference:

CNC Programming & Operations, Sankar, Sathish and Balamurugan – Micro Publications, Tiruchy.

BOARD EXAMINATION

Note: All exercises should be completed. Two exercises should be carried out by selecting one exercise in each section. The printouts must be kept along with the examination paper.

Allocation of marks for Board Examination

PART –A: SOLID MODELING		35
Part modelling	:	15
Assembly	:	10
Printout	:	10
PART-B: CNC PROGRAMING		35
Program editing and creation	:	15
Component manufacturing	:	10
Finish	:	10
Viva voice	:	5
Total	:	75

LIST OF EQUIPMENTS

1. Personal computer - 30 Nos.
2. CNC programming software - Sufficient to the strength.
(Lathe and Milling)
3. Modelling package - Sufficient to the strength.
(Solid works / Pro-E / Catia / Unigraphics / Autocad etc...)
4. CNC Turning Machine - 1 No.
5. CNC Milling Machine - 1 No.
6. Laser Printer - 1 No.
7. Consumables - Sufficient quantity.



DIRECTORATE OF TECHNICAL EDUCATION

DIPLOMA IN AGRICULTURAL TECHNOLOGY

III YEAR

M SCHEME

VI SEMESTER

2015-2016 (on wards)

FARM MACHINERY PRACTICAL

CURRICULUM DEVELOPMENT CENTRE

M – SCHEME

(Implements from the academic year 2015-2016 onwards)

Course Name : DIPLOMA IN AGRICULTURAL TECHNOLOGY
Course Code : 1222
Subject Code : 32365
Semester : VI
Subject Title : **FARM MACHINERY PRACTICAL**

TEACHING AND SCHEME OF EXAMINATION:

No of weeks per semester: 15 Weeks

Subject	Instruction		Examination			Duration
	Hours /week	Hours /Semesters	Marks			
			Internal Assessment	Board Examination	Total	
Farm Machinery Practical	4 Hrs	60 Hrs	25	75	100	3 Hrs

RATIONALE:

Learning theory alone will not suffice for any engineering course. Skill development is one of the major objectives of the diploma programme. To develop various operating and repair, maintenance and service skills on farm machinery the students are given with the farm machinery practical.

GUIDELINES:

All the twelve experiments must be completed and given for end semester practical examination.

A batch of five students may be given a experiment , since the equipments are heavy in nature

The external examiners are requested to ensure that single experimental question should not be given more than four students while admitting a batch of 30 students during board Examinations.

M – SCHEME
32365 – FARM MACHINERY PRACTICAL

COMPLETE LIST OF EXPERIMENTS IN DETAIL

1. Constructional features, Maintenance, Problems and Causes of Mould board Plough
2. Constructional features, Maintenance, Trouble shooting and remedies of Disc Plough
3. Operational procedure of ploughs
4. Constructional features of Disc Harrow, Spike Tooth Harrow and Cultivators
5. Constructional features of seed drill and its calibration
6. Constructional features of various sprayers and their calibration
7. Safety precautions, Maintenance, Trouble shooting and remedies of plant protection equipment
8. Safety precautions, Maintenance, Trouble shooting and remedies of threshers
9. Driving practice of Tractor/Power tiller.
10. Hitching and de-hitching practice of mounted implements (3-point hitch)
11. Visit to nearby Farm Machinery Workshop
12. Major farm machinery manufacturers in India data Collection (Library Visits)

List of equipments required to impart experiment/exercise with number for a batch of 30 students.

1. Mould Board Plough
2. Disc Plough
3. Disc Harrows
4. Seed Drills
5. Sprayers
6. Dusters
7. Reaper and Threshers.

ALLOCATION OF MARKS

Examination Duration: 3 Hrs	Max Marks
Aim	10
Tools used	10
Producer	10
Tractor / Power tiller operation	25
Identification of parts	10
Result	5
Viva-Voce	5
Total	75



DIRECTORATE OF TECHNICAL EDUCATION

DIPLOMA IN AGRICULTURAL TECHNOLOGY

III YEAR

M SCHEME

VI SEMESTER

2015-2016 (on wards)

MACHINESHOP-II PRACTICAL

(MILLING & GRINDING)

CURRICULUM DEVELOPMENT CENTRE

M-SCHEME
(Implements from the Academic year 2011-2012 onwards)

Course Name : DIPLOMA IN AGRICULTURAL TECHNOLOGY
Course Code : 1222
Subject Code : 32366
Semester : VI
Subject Title : **MACHINE SHOP- II (MILLING & GRINDING)**
PRACTICAL

TEACHING AND SCHEME OF EXAMINATIONS:

No. of Weeks Per Semester: 15 Weeks

Subject	Instruction		Examination			Duration
	Hours /week	Hours /Semesters	Marks			
			Internal Assessment	Board Examination	Total	
Milling and Grinding	4 Hrs	60 Hrs	25	75	100	3 Hrs

RATIONALE:

It is very much important to impart basic welding skills to the Diploma Engineer as it is one of the most important manufacturing and salvaging technique. They should be given training to use both milling and grinding machines. The safety precautions should be taught to them. Practice should be given to maintain the milling and grinding machines. Basic skills in lathe should be given to Diploma Engineers. Exposure to the working principles and various kinds of tools and methods of Turning, Drilling operations should be given.

OBJECTIVES:

- Identify a milling machine and its parts.
- Identify a cylindrical grinder, surface grinder and tool and cutter grinder.
- Identify the tools and instruments used in milling.
- Handle the different types of work holding devices.
- Machine a component using different machine tools.

- Calculate the indexing for a work.
- Machine a gear using milling machine.
- Machine a cutting tool using Tool and Cutter grinder.
- Machine a plug gauge using Cylindrical grinding machine.

SYLLABUS

1. Introduction to milling machine and its parts.
2. Introduction to grinding machine and its parts.
3. Introduction to work holding devices.
4. Types of cutter used in milling machine.
5. Types of grinding wheels used in grinding machines.
6. Setting of work, tools and cutters in milling and grinding machines.
7. Operation performed in milling and grinding machines.
8. Operation of milling and grinding machines.

GUIDELINES:

- All the experiments given in the list of experiments should be completed and given for the end semester practical examination.
- In order to develop best skills in handling Instruments/Equipment and taking readings in the practical classes, every two students should be provided with a separate experimental setup for doing experiments in the laboratory.
- The external examiners are requested to ensure that a single experimental question should not be given to more than four students while admitting a batch of 30 students during Board Examinations.

EXERCISES:

1. Prepare a square block from a round rod using milling.
2. Prepare a 'V' Block using Milling machine.
3. Prepare a Groove cut using Milling machine.
4. Prepare a Spur Gear using milling machine by Simple Indexing.
5. Prepare a Plug Gauge using Cylindrical Grinding machine.
6. Prepare Progressive type Plug gauge Progressive type Plug gauge

using Cylindrical Grinding machine.

7. Prepare a Facing Tool using Tool and Cutter Grinder.
8. Prepare a plain surface using surface Grinder.
9. Prepare a Parting Tool using Tool and Cutter Grinder.

Note: Sketches enclosed.

All dimensions in mm.

Note to the faculty :- Last job of the raw material (MS Rod $\text{Ø}32 \times 33\text{mm}$, MS Rod $\text{Ø}25 \times 98\text{mm}$ and $13 \times 13 \times 75\text{ mm}$ MS square rod) to be retained in student wise or batch wise .This may be verifiable at the time of Board Practical Examination by the external examiner.

All Linear dimensions are in $\pm 0.5\text{ mm}$ tolerance and all cylindrical dimensions $\pm 0.2\text{ mm}$ tolerance except grinding operation.

I MILLING:

Exercise No: 1 Raw Material: $\text{Ø} 32 \times 33\text{mm}$ MS rod

Milling a maximum size of square block from a 32mm diameter round rod.

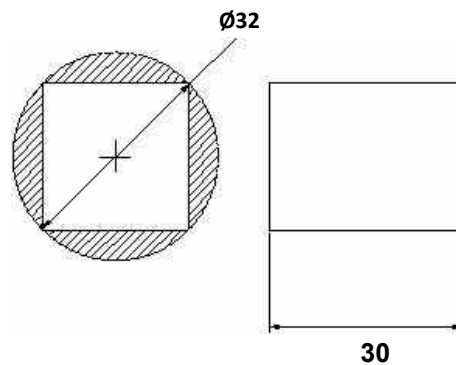

Exercise No: 2 'V' Block Milling

Raw Material: MS square block from exercise 1.

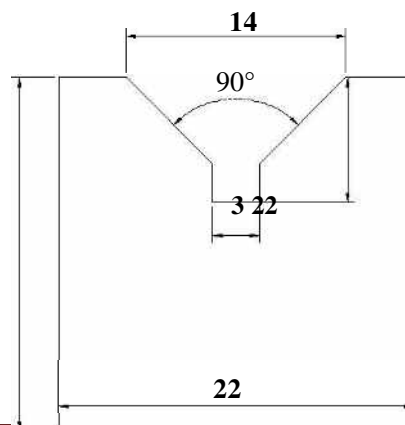

Exercise No: 3 - Groove Milling

Raw Material: Exercise No: 2

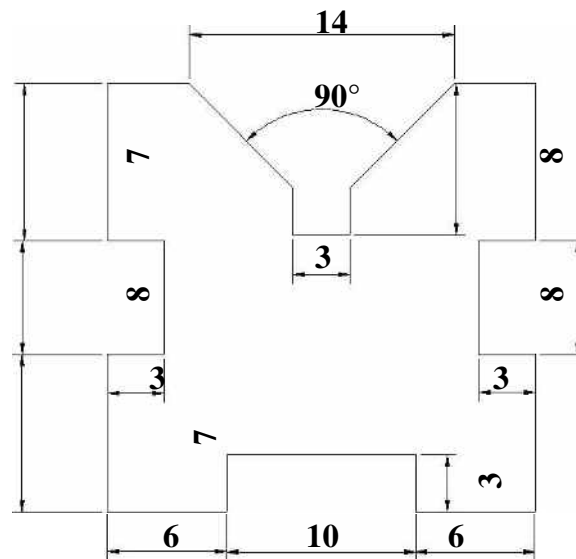

Exercise No: 4- Spur Gear milling (Simple Indexing)

Raw Material: $\varnothing 32 \times 105$ mm MS rod.

Spur Gear, $Z=15, m=1.5$

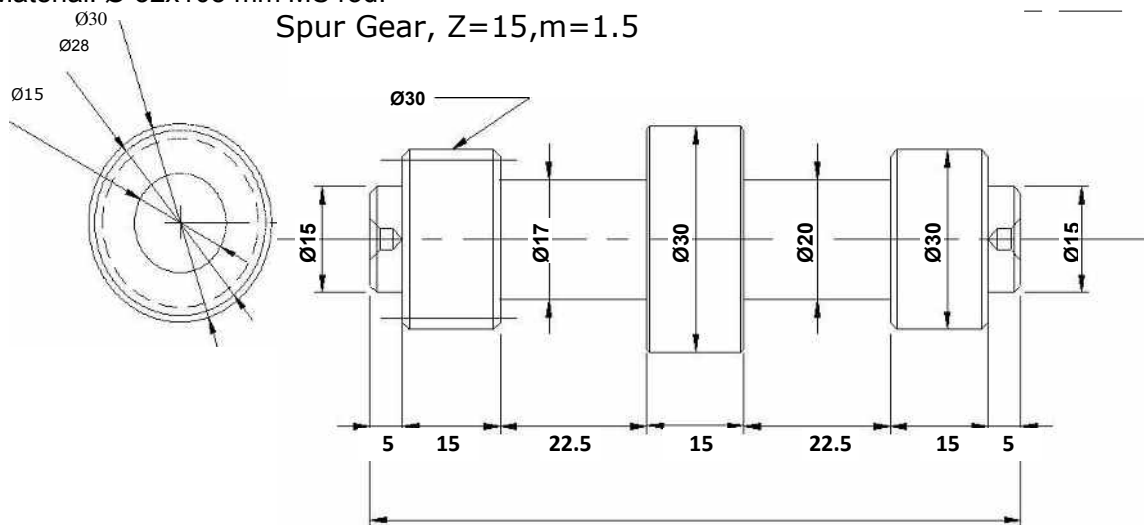

GRINDING

CYLINDRICAL GRINDING

Exercise No: 5- Plug Gauge (Cylindrical Grinding)

Raw Material: Exercise No:4

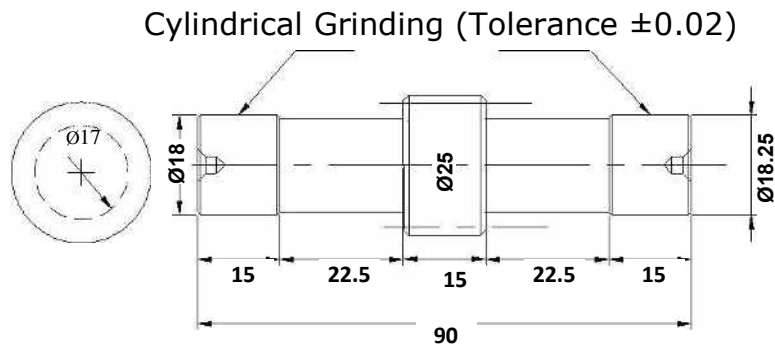

Exercise No: 6- Progressive type Plug gauge (Cylindrical Grinding)

Raw Material: Exercise No: 7

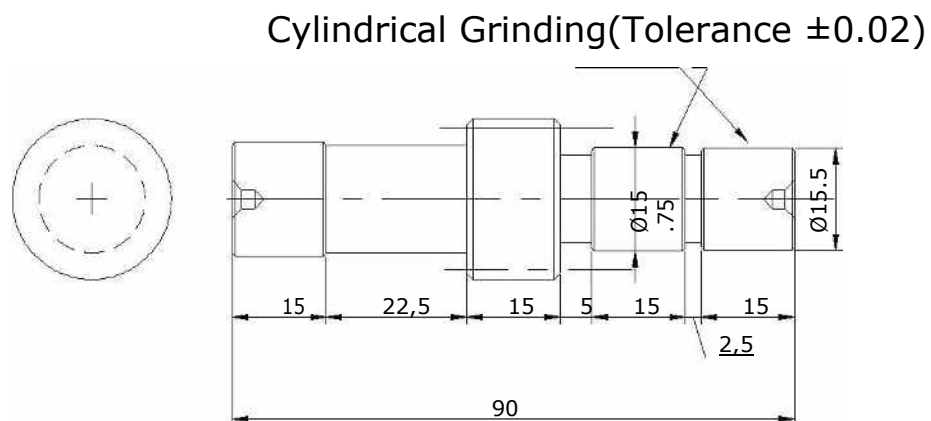

Surface Grinding

Exercise No:8- Surface Grinding

Raw Material: 13x13x75 mm MS square rod

Surface Grinding

Tolerance for 11mm side is ± 0.05

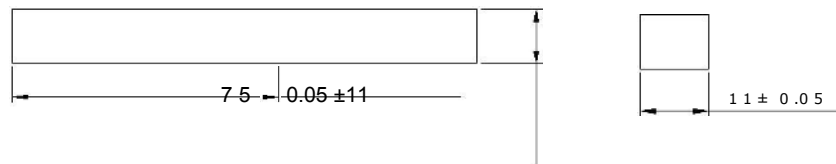

TOOL AND CUTTER GRINDING

Exercise No:9- Facing Tool (Tool and Cutter Grinder)

Raw Material: Exercise No: 8

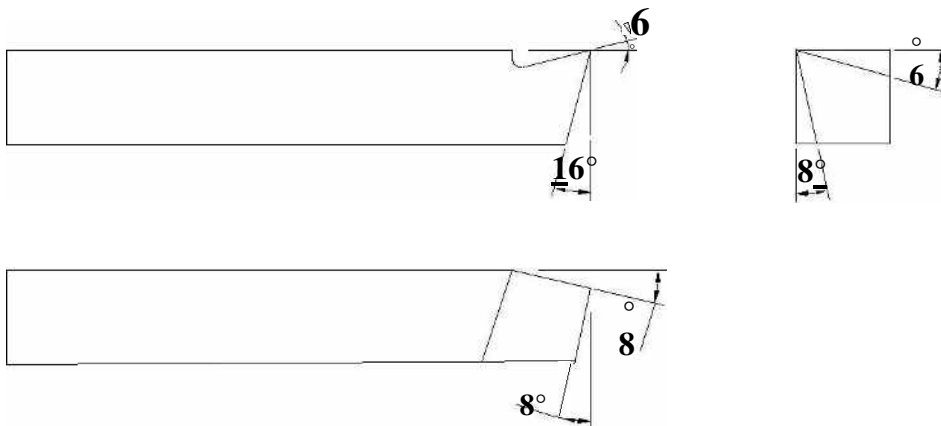

Exercise No: 12- Parting Tool (Tool and Cutter Grinder)

Raw Material: Exercise No: 11

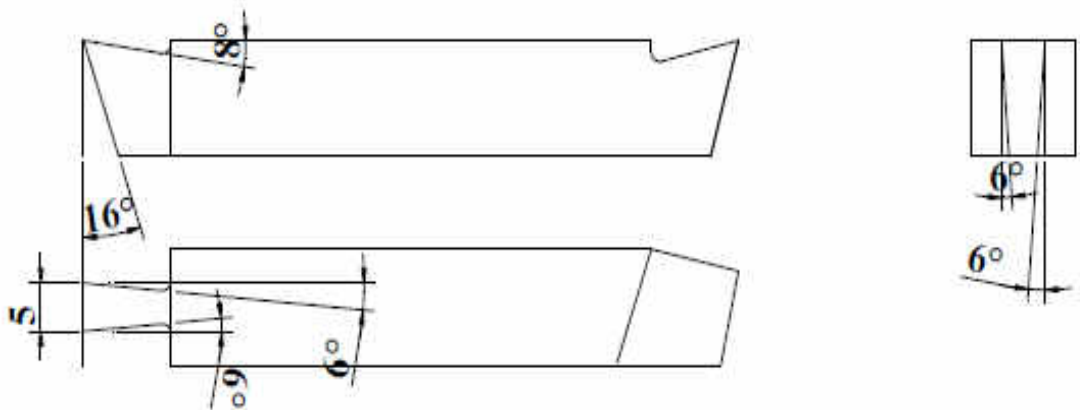

BOARD EXAMINATION

Exercise should be given either in milling or grinding in the Board Examination for 75Marks.

A. Milling Exercise

Milling a V- block from the given round rod

Milling a V- block & groove as in the Ex no3

Milling a spur gear by simple indexing at the centre of the rod

B. Grinding Exercise

Grinding a plug gauge

a. Grinding a rectangular/ square using surface grinding machine

b. Grinding a facing tool using tool and cutter grinder

a. Grinding a rectangular/ square using surface grinding machine

b. Grinding a parting tool using tool and cutter grinder .

Board Examination : 75 Marks

LIST OF EQUIPMENTS

MACHINES:

1. Vertical milling machine/ vertical milling attachment in Universal Milling Machine – 2 No's
2. Universal Milling Machine with indexing head- 2 Nos
3. Surface Grinding Machine (Horizontal) – 1 No
4. Cylindrical Grinding machine – 1 No
5. Tool and Cutter grinder – 1 No

Equipments & Tools:

1. Milling Cutter (2 Module cutter) & accessories – complete sets
2. Milling Machine Handle and required accessories – 2 sets
3. Grinding wheel OD 150 mm , ID 1”(AA-65, K5, V8) – 2 No's
4. Grinding wheel OD 300 mm , ID 150mm(AA-56, K5, V8) – 1No.



DIRECTORATE OF TECHNICAL EDUCATION

DIPLOMA IN AGRICULTURAL TECHNOLOGY

III YEAR

M SCHEME

VI SEMESTER

2015-2016 (on wards)

PROJECT WORK

CURRICULUM DEVELOPMENT CENTRE

M-SCHEME
(Implements from the Academic year 2011-2012 onwards)

Course Name : DIPLOMA IN AGRICULTURAL TECHNOLOGY
Course Code : 1222
Subject Code : 32367
Semester : VI
Subject Title : PROJECT WORK

TEACHING AND SCHEME OF EXAMINATIONS:

No. of Weeks Per Semester: 15 Weeks

Subject	Instruction		Examination			Duration
	Hours /week	Hours /Semesters	Marks			
			Internal Assessment	Board Examination	Total	
Project work	4 Hrs	60 Hrs	25	75	100	3 Hrs

Minimum Marks for Pass is 50 out of which minimum 35 marks should be obtained out of 75 marks in the board Examination alone.

OBJECTIVES:

- Implement the theoretical and practical knowledge gained through the curriculum into an application suitable for a real practical working environment preferably in an industrial environment.
- Get exposure on industrial environment and its work ethics.
- Understand what entrepreneurship is and how to become an entrepreneur.
- Learn and understand the gap between the technological knowledge acquired through curriculum and the actual industrial need and to compensate it by acquiring additional knowledge as required.
- Carry out cooperative learning through synchronous guided discussions within the class in key dates, asynchronous document sharing and discussions, as well as to prepare collaborative edition of the final project report.
- Understand the facts and importance of environmental management.
- Understand and gain knowledge about disaster management.

INTERNAL ASSESSMENT:

The internal assessment should be calculated based on the review of the progress of the work done by the student periodically as follows.

Detail of assessment	Period of assessment	Max. Marks
First Review	6 th week	10
Second Review	12 th week	10
Attendance	Entire semester	5
Total		25

EVALUATION FOR BOARD EXAMINATION:

Details of Mark allocation	Max Marks
Marks for Report Preparation, Demo, Viva-voce	65
Marks for answers of 4 questions which is to be set by the external examiner from the given question bank consisting of questions in the following two topics Disaster Management and Environmental Management. Out of four questions two questions to appear from each of the above topics i.e. 2 questions x 2 topics = 4 questions 4 questions x 2 ½ marks = 10 Marks	10
Total	75

DETAILED SYLLABUS

ENVIRONMENTAL & DISASTER MANAGEMENT

1. ENVIRONMENTAL MANAGEMENT

Introduction – Environmental Ethics – Assessment of Socio Economic Impact – Environmental Audit – Mitigation of adverse impact on Environment – Importance of Pollution Control – Types of Industries and Industrial Pollution.

Solid waste management – Characteristics of Industrial wastes – Methods of Collection, transfer and disposal of solid wastes – Converting waste to energy – Hazardous waste management Treatment technologies.

Waste water management – Characteristics of Industrial effluents – Treatment and disposal methods – Pollution of water sources and effects on human health.

Air pollution management – Sources and effects – Dispersion of air pollutants – Air pollution control methods – Air quality management.

Noise pollution management – Effects of noise on people – Noise control methods.

2. DISASTER MANAGEMENT

Introduction – Disasters due to natural calamities such as Earthquake, Rain, Flood, Hurricane, Cyclones etc – Man made Disasters – Crisis due to fires, accidents, strikes etc – Loss of property and life..

Disaster Mitigation measures – Causes for major disasters – Risk Identification – Hazard Zones – Selection of sites for Industries and residential buildings – Minimum distances from Sea – Orientation of Buildings – Stability of Structures – Fire escapes in buildings - Cyclone shelters – Warning systems.

Disaster Management – Preparedness, Response, Recovery – Arrangements to be made in the industries / factories and buildings – Mobilization of Emergency Services - Search and Rescue operations – First Aids – Transportation of affected people – Hospital facilities – Fire fighting arrangements – Communication systems – Restoration of Power supply – Getting assistance of neighbors / Other organizations in Recovery and Rebuilding works – Financial commitments – Compensations to be paid – Insurances – Rehabilitation.

LIST OF QUESTIONS

1. ENVIRONMENTAL MANAGEMENT

1. What is the responsibility of an Engineer-in-charge of an Industry with respect to Public Health?
2. Define Environmental Ethic.
3. How Industries play their role in polluting the environment?
4. What is the necessity of pollution control? What are all the different organizations you know, which deal with pollution control?
5. List out the different types of pollutions caused by a Chemical / Textile / Leather / Automobile / Cement factory.
6. What is meant by Hazardous waste?
7. Define Industrial waste management.
8. Differentiate between garbage, rubbish, refuse and trash based on their composition and source.
9. Explain briefly how the quantity of solid waste generated in an industry could be reduced.
10. What are the objectives of treatments of solid wastes before disposal?
11. What are the different methods of disposal of solid wastes?

12. Explain how the principle of recycling could be applied in the process of waste minimization.
13. Define the term 'Environmental Waste Audit'.
14. List and discuss the factors pertinent to the selection of landfill site.
15. Explain the purpose of daily cover in a sanitary landfill and state the minimum desirable depth of daily cover.
16. Describe any two methods of converting waste into energy.
17. What actions, a local body such as a municipality could take when the agency appointed for collecting and disposing the solid wastes fails to do the work continuously for number of days?
18. Write a note on Characteristics of hazardous waste.
19. What is the difference between municipal and industrial effluent ?
20. List few of the undesirable parameters / pollutants anticipated in the effluents from oil refinery industry / thermal power plants / textile industries / woolen mills / dye industries / electroplating industries / cement plants / leather industries (any two may be asked)
21. Explain briefly the process of Equalization and Neutralization of waste water of varying characteristics discharged from an Industry.
22. Explain briefly the Physical treatments "Sedimentation" and "Floatation" processes in the waste water treatment.
23. Explain briefly when and how chemical / biological treatments are given to the waste water.
24. List the four common advanced waste water treatment processes and the pollutants they remove.
25. Describe refractory organics and the method used to remove them from the effluent.
26. Explain biological nitrification and de-nitrification.
27. Describe the basic approaches to land treatment of Industrial Effluent.
28. Describe the locations for the ultimate disposal of sludge and the treatment steps needed prior to ultimate disposal.
29. List any five Industries, which act as the major sources for Hazardous Air Pollutants.
30. List out the names of any three hazardous air pollutants and their effects on human health.
31. Explain the influence of moisture, temperature and sunlight on the severity of air pollution effects on materials.
32. Differentiate between acute and chronic health effects from Air pollution.
33. Define the term Acid rain and explain how it occurs.
34. Discuss briefly the causes for global warming and its consequences
35. Suggest suitable Air pollution control devices for a few pollutants and sources.
36. Explain how evaporative emissions and exhaust emissions are commonly controlled.

37. What are the harmful elements present in the automobile smokes? How their presence could be controlled?
38. What is the Advantage of Ozone layer in the atmosphere? State few reasons for its destruction.
39. Explain the mechanism by which hearing damage occurs.
40. List any five effects of noise other than hearing damage.
41. Explain why impulsive noise is more dangerous than steady state noise.
42. Explain briefly the Source – Path – Receiver concept of Noise control.
43. Where silencers or mufflers are used ? Explain how they reduce the noise.
44. Describe two techniques to protect the receiver from hearing loss when design / redress for noise control fail.
45. What are the problems faced by the people residing along the side of a railway track and near to an Airport? What provisions could be made in their houses to reduce the problem?

2. DISASTER MANAGEMENT

1. What is meant by Disaster Management? What are the different stages of Disaster management?
2. Differentiate Natural Disasters and Man made Disasters with examples.
3. Describe the necessity of Risk identification and Assessment Surveys while planning a project.
4. What is Disasters recovery and what does it mean to an Industry?
5. What are the factors to be considered while planning the rebuilding works after a major disaster due to flood / cyclone / earthquake? (Any one may be asked)
6. List out the public emergency services available in the state, which could be approached for help during a natural disaster.
7. Specify the role played by an Engineer in the process of Disaster management.
8. What is the cause for Earthquakes? How they are measured? Which parts of India are more vulnerable for frequent earthquakes?
9. What was the cause for the Tsunami 2004 which inflicted heavy loss to life and property along the coast of Tamilnadu ? Specify its epicenter and magnitude.
10. Specify the Earthquake Hazard Zones in which the following towns of Tamilnadu lie: (a) Chennai (b) Nagapattinam (c) Coimbatore (d) Madurai (e) Salem.
11. Which parts of India are experiencing frequent natural calamities such as (a) heavy rain fall (b) huge losses due to floods (c) severe cyclones
12. Define basic wind speed. What will be the peak wind speed in (a) Very high damage risk zone – A, (b) High damage risk zone, (c) Low damage risk zone.
13. Specify the minimum distance from the Sea shore and minimum height above the mean sea level, desirable for the location of buildings.

14. Explain how the topography of the site plays a role in the disasters caused by floods and cyclones.
15. Explain how the shape and orientation of buildings could reduce the damages due to cyclones.
16. What is a cyclone shelter ? When and where it is provided ? What are its requirements ?
17. What Precautionary measures have to be taken by the authorities before opening a dam for discharging the excess water into a canal/river ?
18. What are the causes for fire accidents ? Specify the remedial measures to be taken in buildings to avoid fire accidents.
19. What is a fire escape in multistoried buildings ? What are its requirements ?
20. How the inmates of a multistory building are to be evacuated in the event of a fire/Chemical spill/Toxic Air Situation/ Terrorist attack, (any one may be asked).
21. Describe different fire fighting arrangements to be provided in an Industry.
22. Explain the necessity of disaster warning systems in Industries.
23. Explain how rescue operations have to be carried out in the case of collapse of buildings due to earthquake / blast / Cyclone / flood.
24. What are the necessary steps to be taken to avoid dangerous epidemics after a flood disaster?
25. What relief works that have to be carried out to save the lives of workers when the factory area is suddenly affected by a dangerous gas leak / sudden flooding ?
26. What are the difficulties faced by an Industry when there is a sudden power failure? How such a situation could be managed?
27. What are the difficulties faced by the Management when there is a group clash between the workers? How such a situation could be managed?
28. What will be the problems faced by the management of an Industry when a worker dies because of the failure of a mechanical device due to poor maintenance? How to manage such a situation ?
29. What precautionary measures have to be taken to avoid accidents to labourers in the Industry in a workshop / during handling of dangerous Chemicals / during construction of buildings / during the building maintenance works.
30. Explain the necessity of medical care facilities in an Industry / Project site.
31. Explain the necessity of proper training to the employees of Industries dealing with hazardous products, to act during disasters.
32. What type of disaster is expected in coal mines, cotton mills, Oil refineries, ship yards and gas plants?
33. What is meant by Emergency Plan Rehearsal? What are the advantages of such Rehearsals?
34. What action you will take when your employees could not reach the factory site because of continuous strike by Public Transport workers?
35. What immediate actions you will initiate when the quarters of your factory workers are suddenly flooded due to the breach in a nearby lake / dam, during heavy rain?

36. What steps you will take to avoid a break down when the workers union of your Industry have given a strike notice?
37. List out few possible crisis in an organization caused by its workers? What could be the part of the middle level officials in managing such crisis?
38. What types of warning systems are available to alert the people in the case of predicted disasters, such as floods, cyclone etc.
39. Explain the necessity of Team work in the crisis management in an Industry / Local body.
40. What factors are to be considered while fixing compensation to the workers in the case of severe accidents causing disability / death to them?
41. Explain the legal / financial problems the management has to face if safety measures taken by them are found to be inadequate.
42. Describe the importance of insurance to men and machinery of an Industry dealing with dangerous jobs.
43. What precautions have to be taken while storing explosives in a match/ fire crackers factory?
44. What are the arrangements required for emergency rescue works in the case of Atomic Power Plants?
45. Why residential quarters are not constructed nearer to Atomic Power Plants?
